

Start-up instructions

Thyristor controller Type: TS3 1Ph, TS3 SP 1Ph Single phase controller W1C

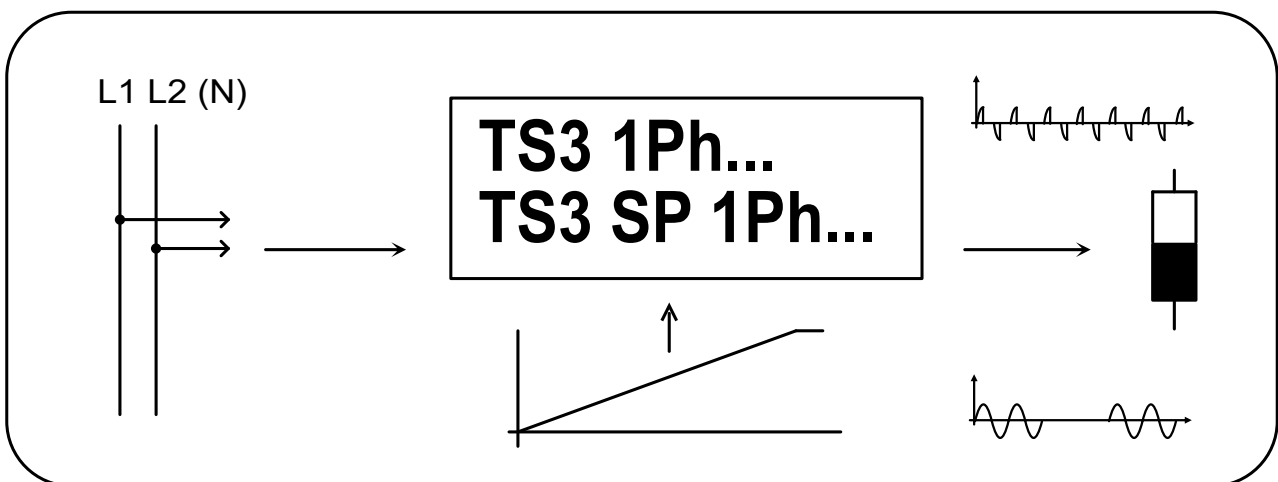

Content

	Seite
1. Important safety instructions.....	2
2. General instructions.....	2
3. Technical explanations on thyristor controllers.....	3
3.1 Explanation phase angle control.. Ph.....	4
3.2 Explanation multicycle control (burst-firing control).....	5
4. Installation of the thyristor controller TS3 1Ph, TS3 SP 1Ph.....	6
5. EMC-equitable assembly.....	6
6. Operation.....	8
7. Meaning of the clamp connections.....	9
8. Meaning of LEDs.....	10
9. Basic circuit.....	11
10. Survey of the individual types.....	12
11. Technical data.....	13
12. Equipment.....	13

1. Important safety instructions

This manual contains notes that you must observe for your personal safety and to prevent damage to property. The notes on your personal safety are highlighted by a warning triangle with three exclamation points, instructions for sole property damage are marked with a warning triangle and an exclamation mark.



Danger-symbol

Personal injury **may** occur, if appropriate safety precautions are not taken.



Caution-symbol

Material damages may occur, if appropriate safety precautions are not taken into account.



Disposal regulations

The devices contain electrical components and must not be disposed together with household garbage. The devices for disposal have to be recycled according to local and currently valid regulations for electronic waste.

Qualified personnel

The corresponding device/system may only be set up and operated in conjunction with this documentation. Commissioning and operation of the device/system may only be performed by **qualified personnel**. Qualified personnel within the meaning of the safety instructions in this documentation are persons with the authority to put electric circuits into operation, provide ground connections and label them according to current safety regulations.

The device should only be used in applications described in this document. The reliable and proper use of the product depends on appropriate transport, storage, installation and careful commissioning.

2. General instructions

Use of the document

This instruction should demonstrate the technical application possibilities of the thyristor controller to the engineer in charge.

Target group

The document should assist the user during commissioning. It also helps in case of service and maintenance work. It supports the planner and project engineer with the conception of new plants.

Necessary competence

Generic skills in the field of electrical engineering are necessary.

Validity

This document is valid for the thyristor controller TS3 1Ph, TS3 SP 1Ph. It contains the currently valid description of the device. We reserve the right to attach new descriptions of the devices, versions and options with modified version to the technical documentation.

Standards and approvals

The TS3 1Ph, TS3 SP 1Ph thyristor controllers are based on the IEC / EN 60947-4-3 standard.

Disclaimer

It lies within the responsibility of the plant manufacturer of the technical equipment or machine to ensure the proper overall function. The producer can not guarantee all properties of the overall system or the machine.

3. Technical explanations on thyristor controllers

The thyristor controller is more and more used in sectors, in which bigger loads of ohm and inductive loads have to be regulated (i.e.: building of industrial furnaces, plastics processing, etc.).

Due to its modular, compact construction and its controlling by a continual control signal, these wattage regulators become a perfect device for industrial control of wattage input. The power element of the thyristor controller consists at the TS3 1Ph... of two, at the TS3 3Ph of six antiparallel connected thyristors, the isolated cooling system and the electronic regulation and watching.

Type description:

TS3 1Ph...	single phase controller, phase angle control
TS3 SP 1Ph...	single phase controller, multicycle control
TS3 3Ph...	three phase controller, phase angle control
TS3 SP 3Ph...	three phase controller, multicycle control

Auxiliary Voltage:

The devices are powered internal by the mains voltage. Optional can devices with different mains voltage be supplied with an external auxiliary voltage.

Construction:

The thyristor controllers comply with the Low Voltage Directive: 2014/35 / EU, EN60947-4-3 and EMC Directive: 2014/30 / EU, EN60947-4-3 Ki.A

The thyristor controller TS3 1Ph... is assembled modularly. It consists of two basic elements

- power unit with heat sink and thyristor wiring
- control and monitoring unit with ignition electronics (diagnostic display, control output, etc.)
- optional can devices with different mains voltage be supplied by an external auxiliary voltage

3.1 Explanation phase angle control Ph

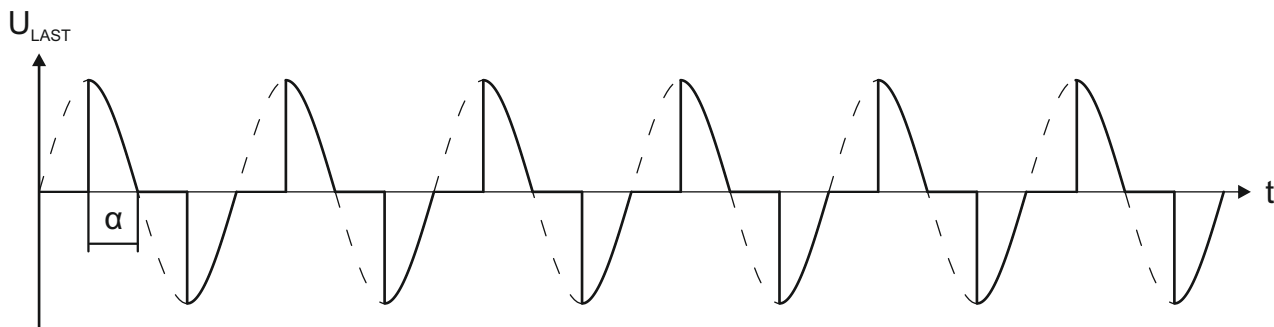

The phase angle control is an electrotechnical method to regulate the electrical power of loads with single phase current or three phase current. A typical use of this technology is dimming of light bulbs and various inductive and ohmic components. The effective value of the voltage as well as the electrical power consumption of the load can be changed by altering the switch-on moment. For many electrical engines with suitable construction (for example universal motors, asynchronous motors, fan motors or pump motors) a phase angle control can be used to control speed and torque. Due to the controllability of the positive and negative half-wave it is possible to adjust exactly the load voltage and to implement precise control applications. The variation of the phase angle α also allows the control of transformers for softstart- and control applications.

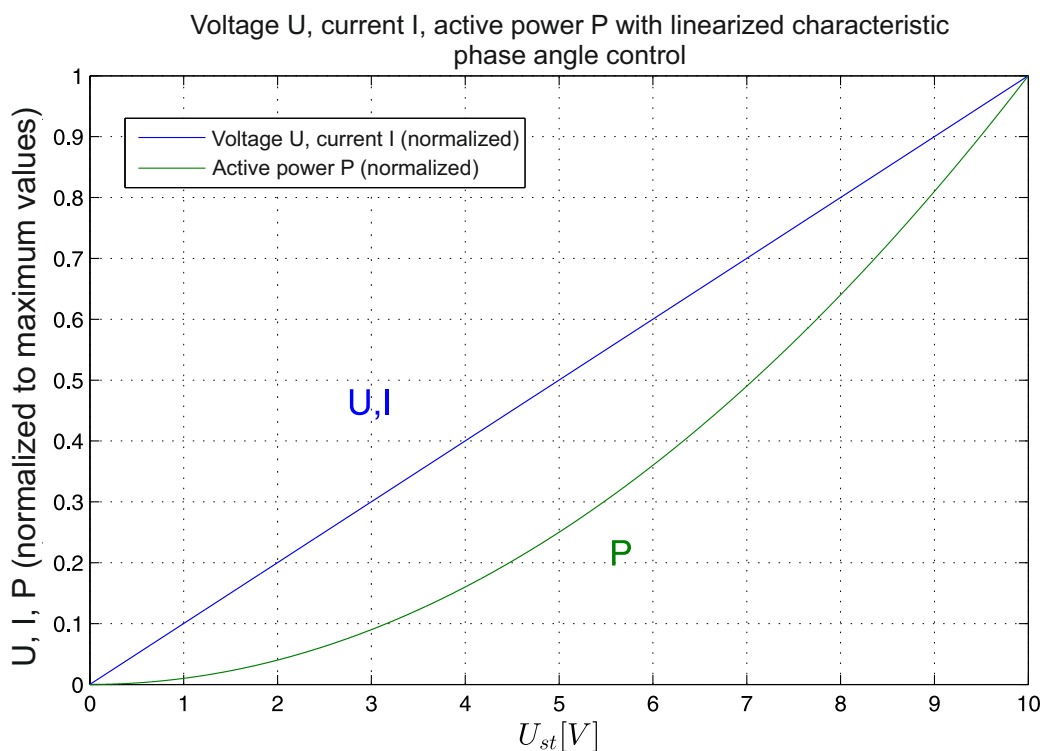

U_{max}
 I_{max}
 P_{max}

$$P = U_{max} \cdot I_{max} \cdot \left(\frac{U_{st} [V]}{10V}\right)^2$$

$$U = U_{max} \cdot \frac{U_{st} [V]}{10V}$$

$$I = I_{max} \cdot \frac{U_{st} [V]}{10V}$$

3.2 Explanation multicycle control SP (burst-firing control)

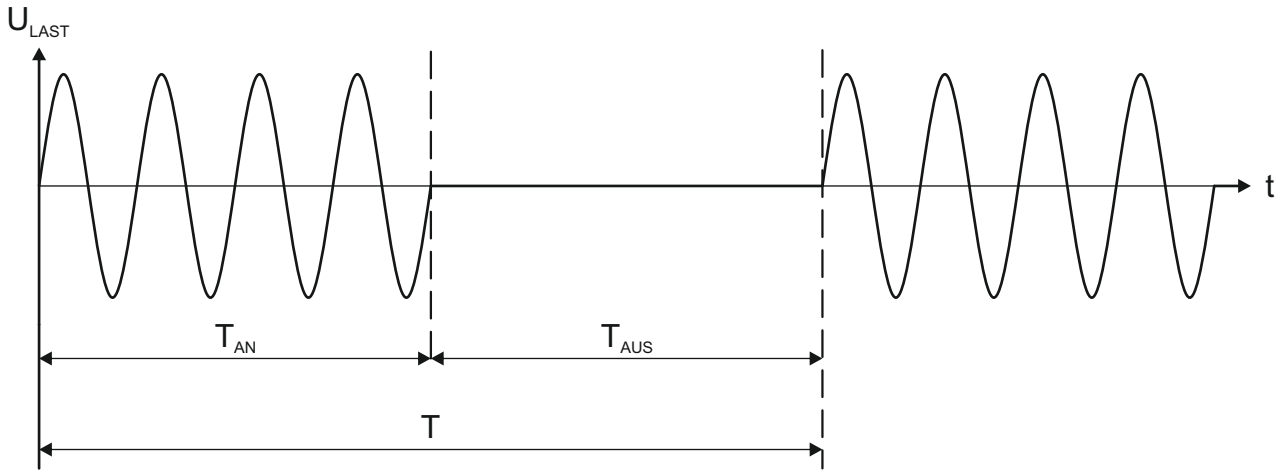

In this operating mode the thyristor controller ensures the targeted switching of individual full waves of the power supply. Depending on the control signal individual halfwaves (positive half-waves, negative half-waves) and wave packets can be switched, in which the switching point is always at the sinus zero crossing. The impulse(T_{AN})-pause(T_{AUS})-ratio controls the electrical power. This kind of operation mode reduces system perturbation. As basis for the switching intervals (impulse-pause-ratio) the devices normally operate with a time base T of one second (1s corresponds to 50 full-waves). Possible application areas are electric heatings, heat technology, and drying technology.

For example:

A control signal of $U_{st} = 5V$ with a control range of 0 to 10V creates a impulse duration T_{AN} of 25 full-waves (500 ms) and a pause duration T_{AUS} of 25 full-waves (500ms).

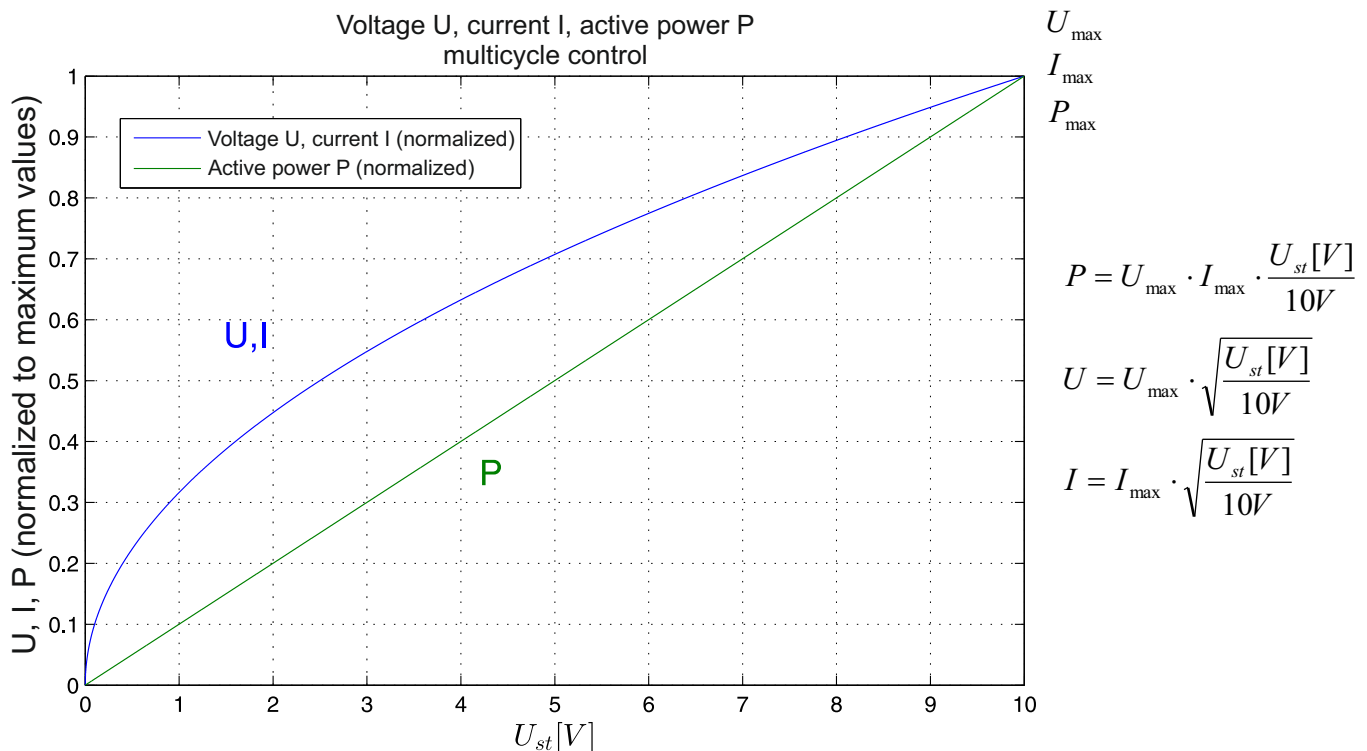

4. Installation of the thyristor controller TS3 1Ph, TS3 SP 1Ph

The built-in device, according to IP 40 has to be mounted in a housing or a switchboard panel. Take care of adequate cooling (separate ventilation, for instance). The environment temperature must not exceed the value of 50°C. The device is to be mounted on a vertical plane, avoiding that the ventilating pipes of the cooling element are not placed vertical. The device has to be mounted in a dry room.

Further conditions to the operating area:



- protection from dust and moisture
- protection from aggressive atmosphere
- free from vibrations

No other devices should be placed closer than 50 to 100mm to the device, in order to provide adequate cooling.

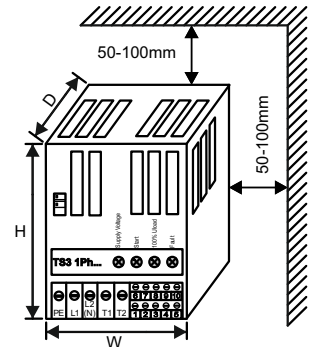

The housing equipment according to IP 54 can be placed in locations which are not protected from dust and moisture.

Wiring the device:



Build mains connection L1, L2, L3. (N) via fused circuit breakers with usual fuses.

The wiring for power supply and the wiring for control have to be laid in separate conduits or shield ducts.

It is essential to the electric installation to comply to the stipulations of the VDE (German Electrical Engineers Association), specifically to VDE 0100, VDE 0113, VDE 160.

5. EMC-equitable assembly

According to EMC standards thyristor controllers are regarded as components, which do not fulfil any intended use by themselves. The devices constitute a functional unit of the entire plant. The control electronics of the thyristor controllers are implemented according to valid EMC standards.

The builder of the plant has to supply the plant with appropriate mains chokes and mains filters. These components can also be obtained from us. Thyristor controllers with multicycle control usually do not require any additional mains filter circuit.

It should be noted that the standards of the resource category A are not sufficient in a special industrial sector, for example if sensitive measuring channels are affected. In this case, the user has to apply equipment of class B.

The class A is the usual class of equipments, which is normally intended for the use in the industrial sector. The devices are connected to the industrial network via an assigned transformer. Power controllers of class B are required if they should be used in the area of industry and small-scale industry and if they should be connected to the public low-voltage system.

Use of mains chokes:

On the input side of the thyristor controllers, mains chokes reduce the current-dependent line reactions and effect an improvement of the performance factor. This reduces the current harmonics and improves the mains quality. The use of mains chokes is particularly recommended when connecting thyristor controllers with phase angle control to a grid-feeding point and when other electronic devices are attached to this network.

Use of mains filters:

Radio interference filters and mains filters (combination of radio interference filter and one mains choke) serve for protection against high-frequency disturbances, which are sent out via the power cable or the radiation of the power cable. The high-frequency disturbances should be limited to a mandatory or legal degree. Mains filters should possibly be mounted close to the thyristor controller and moreover it is necessary to ensure that the connecting cable between the thyristor controller and the mains filter is as short as possible.

CAUTION: The mounting surfaces of the thyristor controllers and the radio interference filters have to be free from paint and well conducting in the high-frequency range.

Furthermore, mains filters have leakage currents, which may become significantly larger than the nominal values in case of failure (phase failure, unbalanced load). To avoid dangerous voltages, the mains filters have to be grounded. As the leakage currents are high-frequent disturbances, the grounding measures have to be low-resistance and extensive.

With leakage currents, which exceed the value of 3,5mA, VDE 0160 or EN 60335 specify that either:

- the cross section of the protective conductor has to be $\geq 10\text{mm}^2$,
- the protective conductor has to be monitored on interruption or
- a second protective conductor has to be laid.

Shielding measures:

Shielding measures help to reduce the radiated interference energy. Electrical lines between thyristor controller and load can be laid shielded. Thereby the shield must not replace the PE line. Four-wire cables (three phases + PE), whose shield is double-sided and extensive laid on earth potential (PES), are recommended. The shield must not be applied over the connecting wires. Interruptions of the shielding e.g. in the case of clamps, contactors, mains chokes etc. have to be bridged with low-resistance and appropriate space considerations.

In practice this can be done for example by interrupting the shield close to the assembly and then connecting it extensively with the earth potential (PES, shield clamp). The free cables, which are not shielded, should not be longer than 100mm.

Grounding measures:

Grounding measures are absolutely necessary to fulfil legal provisions. They constitute a prerequisite for an efficient use of further measures such as filters and shielding. All conductive, metallic housing components have to be electroconductive connected with the earth potential. For the EMC-measure, the important factor is not the cable's crosssection, but its surface, since this is where high frequency current flows to earth. Once again, all grounding points have to be led directly, extensively and with low-resistance to the central grounding point (equipotential bonding bar, star-shaped grounding system). The contact points have to be free from paint and corrosion (use galvanized mounting plate and materials).

6. Operation



To begin with, the electrical connections are to be done, according to the accompanying plans: L1, L2 (N), T1, T2. The thyristor controller have to be connected to the power supply according to the VDE rules, in a way that they can be disconnected again by appropriate switching means (i.e. master switch, contactor, protective power switch).

Conducting wire installation:

The power supply, the user supply, as well as the control wiring have to be placed in separate ducts or conduits.

To avoid malfunction, it is advisable, to install the electronic signal wiring separated from the power supply and/or from the protective control wiring as well as to twist the feed and return signal lines or use shielded control lines (see also point 5. EMC-equitable assembly).

Fuses:

The mains fuse protection depends on the recommended or employed power-transmission crosssection and has to be carried out, according to DIN 57100, part 430/VDE 0100 and part 430/6.81.

General information:

Thyristor controller for phase angle (TS3 1Ph... and TS3 3Ph...) serve to control ohmic and inductive loads. The activation is standardly made via proportional signals (0...10V, 0...20mA or 4...20mA). The phase angle or the input and output clock ratio with multicycle control (TS3 SP 1Ph... and TS3 SP 3Ph) is constantly adjusted by the control electronics, to achieve an adequate proportionality between the activation of the thyristor controller and the output (T1, T2).

Beside these already mentioned device series, TS3 1Ph... and TS3 3Ph..., we also have single-phase and three-phase versions, which cover the upper voltage range up to 2500A. These devices are also for short delivery.

Devices in special designs are also available after clarification of the technical specifications and adjustment with our technicians.

7. Meaning of the clamp connections

Clamps	Function	State	Description of the function
1-2	start	geschlossen	softstart and operation will be activated
		open	ready for operation
3	U_{ref}	10V	reference voltage 10V DC (voltage supply for potentiometer control)
4	$U_{control}$	0-10V 0-20mA 4-20mA 2,5-10k Ω (Poti)	input of voltage and current signal or potentiometer control
5	ground (GND)	X	Ground for current, voltage or potentiometer control
6-7	fault relay output	clamps 6, 7 closed	over temperature of the power unit
8-10	not connected (n.c.)	X	X
L1-L2(N)	mains connection (U_{Netz})	230V/50Hz	rated voltage
T1-T2	load connection	$U_{last} = 0 \dots 100\% U_{Netz}$ (corresponding to mains voltage on L1-L2(N))	load (heating resistor, motor, transformer)

Control with voltage signal:

Switch (Ri1, Ri2)	set 0-10V	
Klemme:	4	control input
	5	ground (GND)

Adjustment of the switch "Ri1" and "Ri2" for control input:

0...10V

Ri1

Ri2

Control with current signal:

Switch (Ri1, Ri2)	set 0-20mA or 4-20mA	
Klemme:	4	control input
	5	ground (GND)

0...20mA

Ri1

Ri2

4...20mA

Ri1

Ri2

Control with potentiometer:

Switch (Ri1, Ri2)	set 0-10V	
Clamp:	3	reference voltage (10V, supply voltage for potentiometer)
	4	sliding contact
	5	ground (GND)

0...10V

Ri1

Ri2

Note:

The black square on the switch picture shows the slide control.

Slide control 

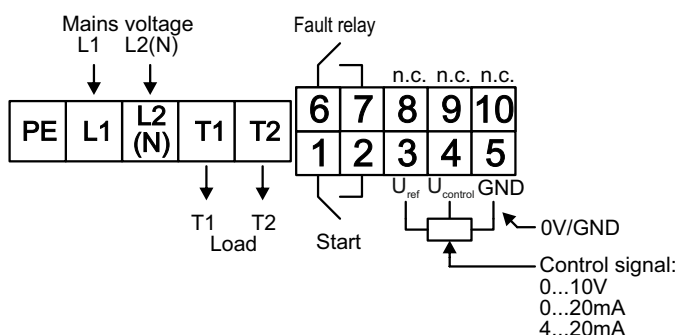

8. Meaning of the LEDs

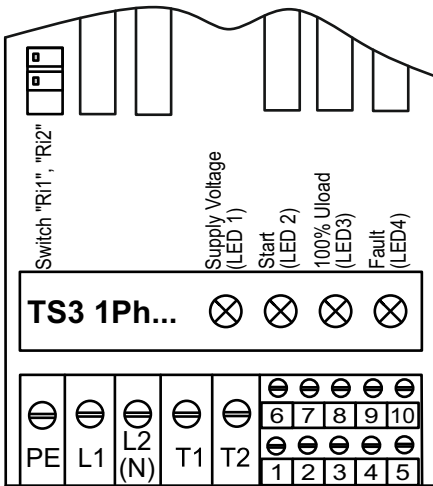

LED 1	green	lights by internal supply of the control electronics. Mains voltage U_{Mains} is connected to terminals L1, L2(N).
LED 2	yellow	lights if "Start" (clamps 1, 2) are bridged
LED 3	yellow	lights if load voltage U_{Load} has reached 100%
LED 4	red	lights at over temperatur of the power unit. The load voltage will be deactivated at 90°C. To reset the fault open the Start contact (clamps 1, 2) and perform a restart (close clamps 1, 2).

Diagnosis chart:

Pos.	LED 1	LED 2	LED 3	LED 4	State	Fault relay output (at the same time with LED 4)
1	green	*	*	*	<ul style="list-style-type: none"> device is ready for use 	
2	green	yellow	*	*	<ul style="list-style-type: none"> device is ready for use start is enabled (clamps 1, 2 are bridged) 	
3	green	yellow	yellow	*	<ul style="list-style-type: none"> device is ready for use start is enabled U_{Load} is 0-100% 	
4	green	*	*	red	<ul style="list-style-type: none"> device is ready for use fault is activated 	clamps 6, 7 closed
5	green	yellow	*	red	<ul style="list-style-type: none"> device is ready for use start is enabled fault is activated 	clamps 6, 7 closed

* no change

9. Basic circuit

Device type with 230V AC main voltage (TS3 1Ph...230V / TS3 SP 1 Ph...230V)

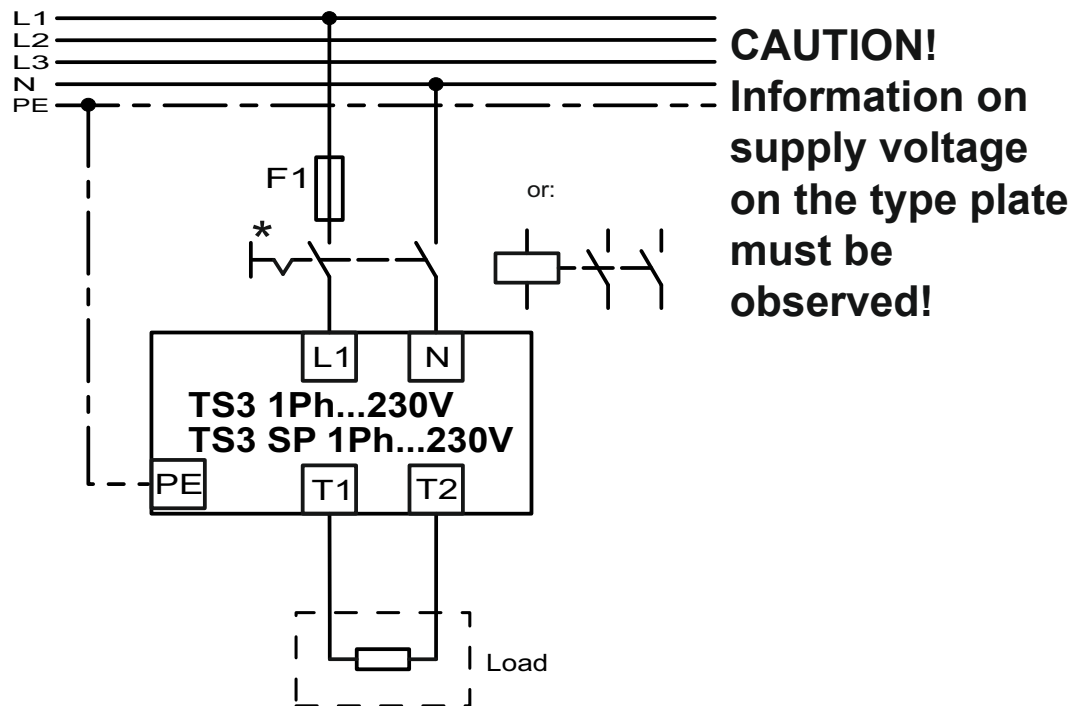

Device type with 400V AC main voltage (TS3 1Ph...400V / TS3 SP 1Ph...400V)

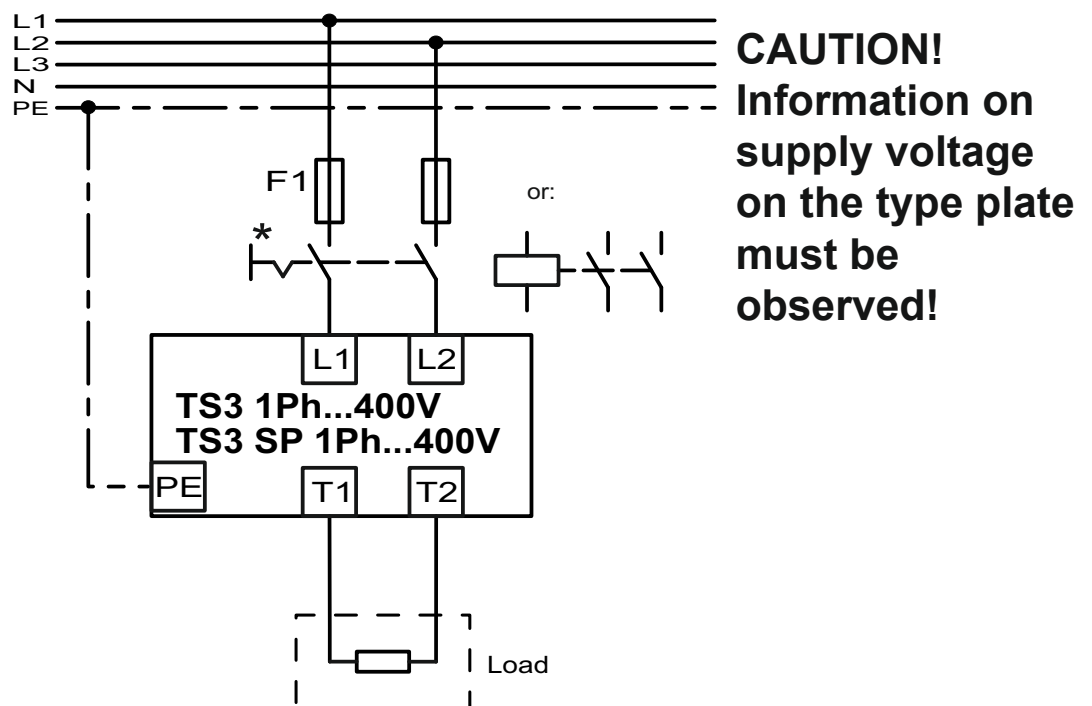

* For disconnection plug connectors, fuses, circuit-breakers, load-breakers, residual current devices (RCDs), etc. can be used.

10. Survey of the individual types

Type	max. load current	rec. semiconductor fuses	Mains fuse	rec. cross-section	max. power (230VAC)	max. power (400VAC)*	Power lose at nominal rating	Weight	Dimensions WxHxD (with assembly for mounting on a DIN rail)
	[A]	[A]	[A]	[mm ²]	[kW]	[kW]	[W]	[kg]	[mm]
TS3 1Ph 05	5	10	16	2,5	1,1	2,0	4	0,8	92x128x105
TS3 1Ph 15	15	25	25	2,5	3,4	6,0	13	0,8	92x128x105
TS3 1Ph 25	25	30	32	4	5,7	10,0	22	0,8	92x128x105
TS3 1Ph 35	35	40	50	6	8,0	14,0	31	0,8	92x128x105
TS3 1Ph 50	50	60	80	10	11,5	20,0	45	0,8	92x128x105

*modell dependent

Errors and technical modifications excepted (Date 2021/11)

- The given details also apply to the version with multicycle control TS3 SP 1Ph...

The values given for overload refer to a sur-rounding temperature exceed of max. 50°C and an installation altitude of 1000m. Semiconductor fuses can be ordered optionally.

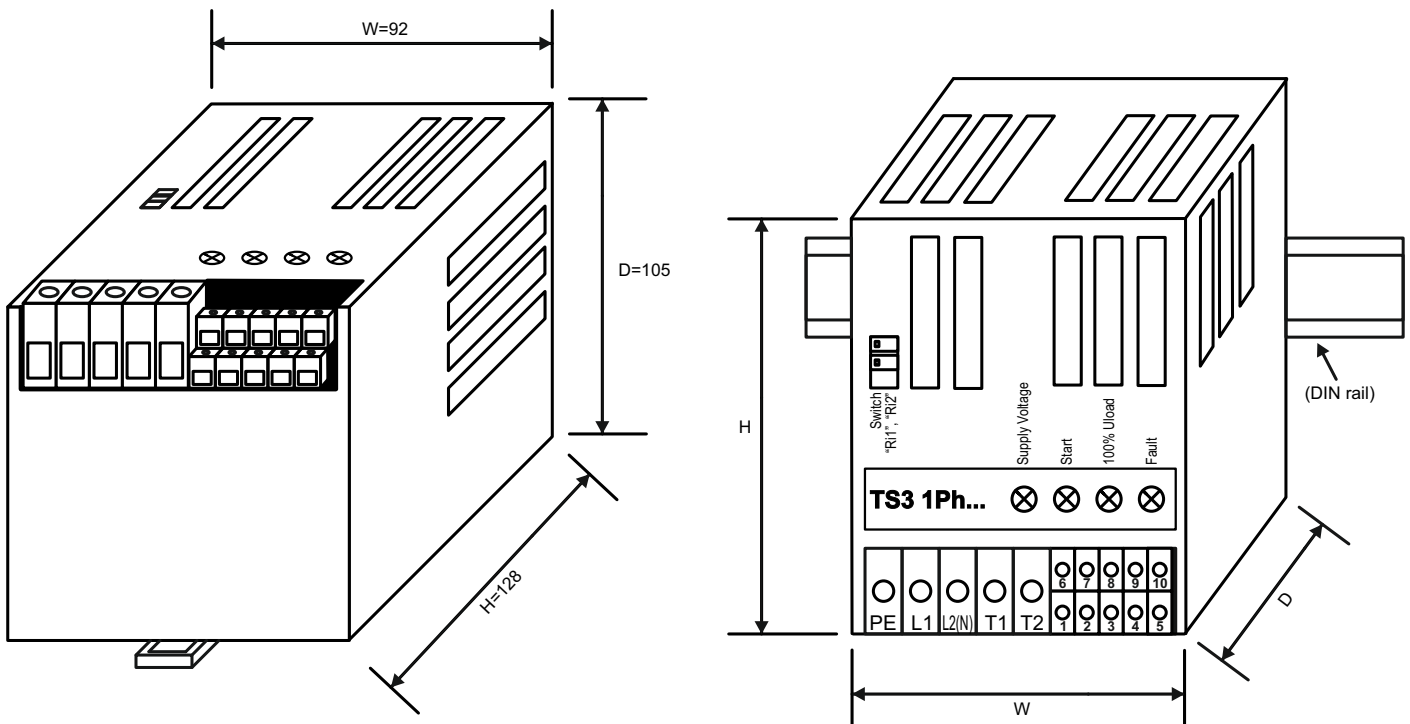

11. Technical data

Mains voltage	230V AC \pm 15% (optional: other mains voltages available)
Rated controller current	see table on page 12 (05...50A)
Auxiliary voltage	generation internally
Frequency	45 - 65Hz, self-synchronizing
Input	<ul style="list-style-type: none"> • 0 - 10V • 0 - 20mA • 4 - 20mA • potentiometer input: 2,5 - 10kΩ
Input impedance	<ul style="list-style-type: none"> • voltage input signal: 1MΩ • current input signal: 500Ω
Protection system	deactivation at over temperature indicated by LED Fault
Display of the operating states	auxiliary voltage, Start, 100% U _{Load} , Fault
Softstart time	2 sec.
Outputs	fault indication: clamps 6, 7 closed, Contact rating: 2A, 230V AC, AC1
Power terminals	<ul style="list-style-type: none"> • L1, L2 (N) input voltage • T1, T2 output voltage
Kind of controlling	phase angle control (optional: multicycle control)
Power loss	0,9W/A
Operating temperature	0 - 50°C
Storage temperature	-10 - 70°C
Humidity	5% - 95% relative humidity, not condensing
Environment	dry, non-conducting environments
Max. altitude	1000m
Weight	0,8kg
Protection	IP 40
Dimensions (WxHxD)	92x128x105mm
Mounting	mounting on a DIN rail (Option: mounting on mounting plate)
CE-regulations	EMC Directive 2014/30/EU Low voltage Directive 2014/30/EU RoHS Directive 2011/65/EU

Errors and technical modifications excepted (Date: 2021/09 Rev. 03-2024)

12. Equipment

- mains filter
- mains choke