

SAB05

EasySens wireless radiator valve actuator for room temperature control

thermokon[®]
HOME OF SENSOR TECHNOLOGY

Datasheet

Subject to technical alteration
Issue date: 01.02.2023 • A120



» APPLICATION

Wireless valve actuator for bidirectional EnOcean communication. The SAB05 combines with message server and enocean transmitter.

» TYPES AVAILABLE

Valve actuator EnOcean
SAB05 EEP A5-20-01

» SECURITY ADVICE – CAUTION



The installation and assembly of electrical equipment should only be performed by authorized personnel.

The product should only be used for the intended application. Unauthorised modifications are prohibited! The product must not be used in relation with any equipment that in case of a failure may threaten, directly or indirectly, human health or life or result in danger to human beings, animals or assets. Ensure all power is disconnected before installing. Do not connect to live/operating equipment.

Please comply with

- Local laws, health & safety regulations, technical standards and regulations
- Condition of the device at the time of installation, to ensure safe installation
- This data sheet and installation manual

» PRODUCT TESTING AND CERTIFICATION



Declaration of conformity

The declaration of conformity of the products are available on our website <https://www.thermokon.de/>.

» NOTES ON DISPOSAL



As a component of a large-scale fixed installation, Thermokon products are intended to be used permanently as part of a building or a structure at a pre-defined and dedicated location, hence the Waste Electrical and Electronic Act (WEEE) is not applicable. However, most of the products may contain valuable materials that should be recycled and not disposed of as domestic waste. Please note the relevant regulations for local disposal.

» TECHNICAL DATA

| | |
|-----------------------|--|
| Radio Technology | EnOcean (IEC 14543-3-10), transmission power <10 mW |
| Frequency | 902 MHz |
| Antenna | internal transmitting/receiving antenna |
| Data transmission | bidirectional, airConfig ready |
| Power supply | Battery-operated, 3 Alkaline batteries (type AA, LR6AD Panasonic Powerline 1,5 V) |
| Measuring range temp. | +32..+104 °F |
| Measuring interval | every 2..20 Min, configurable via airConfig (in 2-min increments) or Button |
| Transmission interval | = Measuring interval |
| Functions | radio interface, actuator operation, self-control mode, automatic closing point control, frost protection function |
| Display | Status-LED, multicolored |
| Enclosure | RAL 9010 pure white, battery compartment cover with mechanical locking Mechanism |
| Protection | IP40 according to EN 60529 |
| Ambient condition | +32..+122 °F, max. 85% rH non-condensing |
| Mounting | screw mounted, M30 x 1,5 |
| Notes | configuration software "airConfig" can be downloaded from Thermokon website. EnOcean USB stick, (i.e. contained in the test tool airScan (item No. 566704) will be required to communicate. Integrated temperature sensor, Operational noise <28 dB(A), Nominal stroke up to 0.12 in., Travel time 2,5 s/0.01 in., Positioning force 100 N nominal |

» INFORMATION ABOUT EASYSSENS® (RADIO) / AIRCONFIG GENERAL USAGE



EasySens® - airConfig

Basic information about EasySens® radio and about general usage of our airConfig software, please download from our website.

» OVERVIEW OF THE RADIO TELEGRAMS



EEP

The structure of the data contained in the telegram can be found in the EEP (EnOcean equipment profile) list provided by the EnOcean Alliance.

» MOUNTING ADVICES

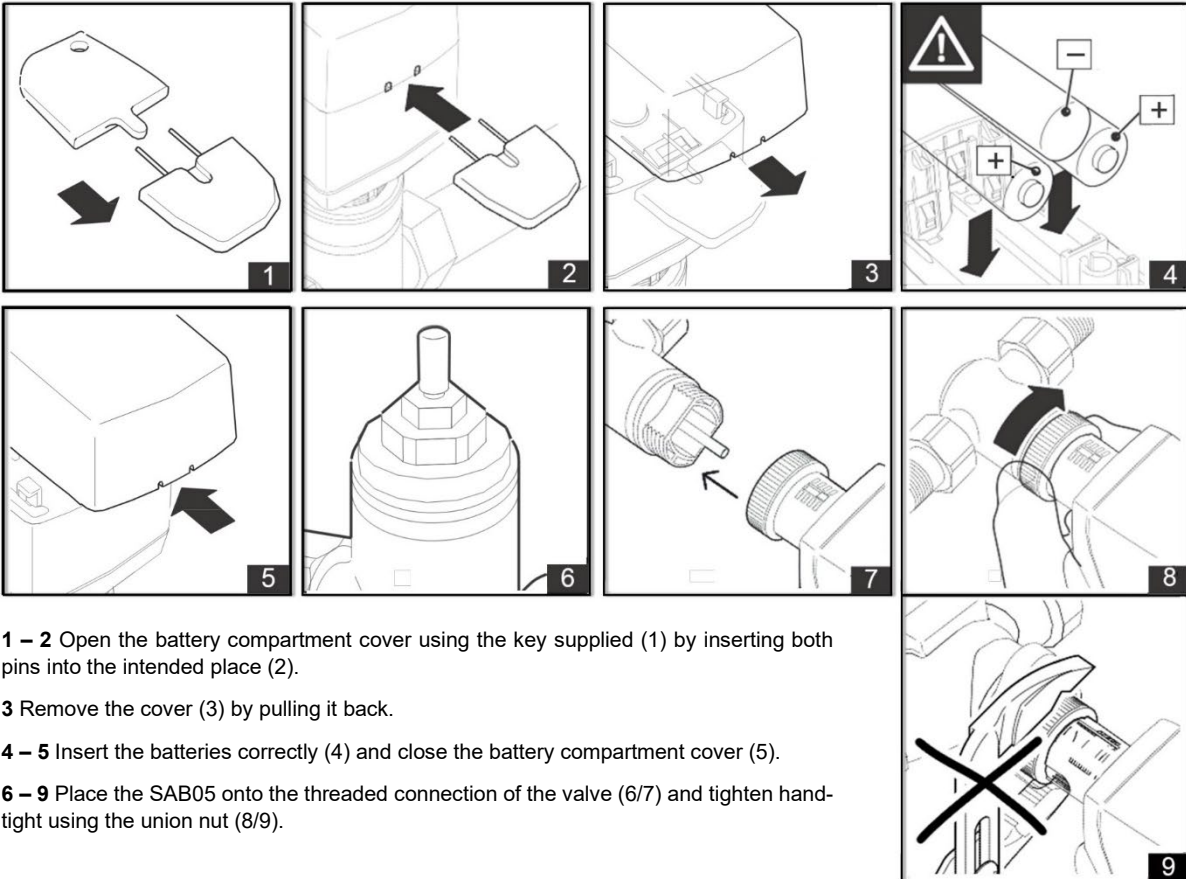
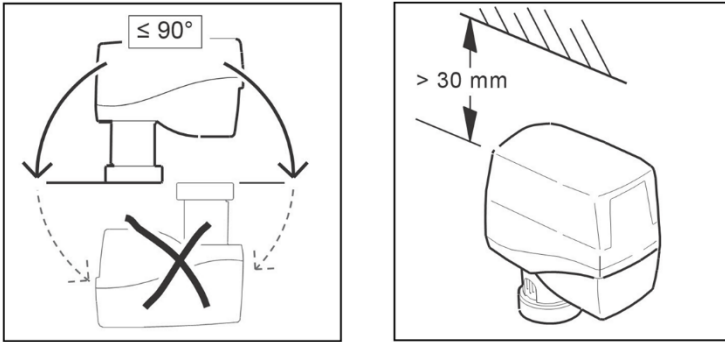

- 1 – 2 Open the battery compartment cover using the key supplied (1) by inserting both pins into the intended place (2).
- 3 Remove the cover (3) by pulling it back.
- 4 – 5 Insert the batteries correctly (4) and close the battery compartment cover (5).
- 6 – 9 Place the SAB05 onto the threaded connection of the valve (6/7) and tighten hand-tight using the union nut (8/9).

NOTE:

When inserting the batteries, consider the polarity as marked in the battery compartment. Use only alkaline batteries (type: AA, LR6 1,5 V). Rechargeable batteries (accumulators) are not permitted.
 After changing the batteries, SAB05 enters storage mode and retracts the actuator spindle. When the actuator receives a wireless signal, it switches over to normal operation.
 Learn-in shall take place within one hour after the batteries have been inserted. If the learn-in has not been done within 1 hour, SAB05 enters the self-controlled mode and controls the temperature from its internal temperature sensor.

» OPERATING ELEMENTS

The buttons and LEDs that are used during commissioning are located inside the housing. Remove the housing cover before commissioning.

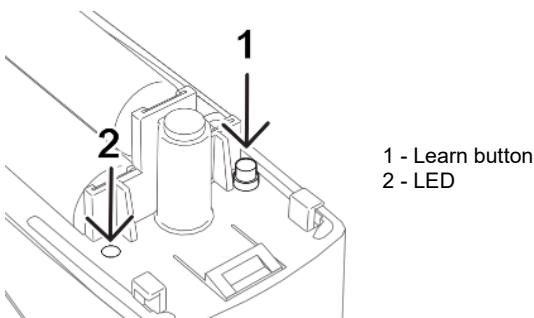

» FUNCTION DESCRIPTION

Wireless Interface

The communication with the MSG-Server or bidirectional gateway is cyclical, bidirectional and includes intelligent reception/transmission management.

Upon the first reception of the wireless telegram, SAB05 automatically adapts its operating mode according to the method of control from the MSG-Server or bidirectional gateway (actuator mode or self-controlled mode).

If the communication with the MSG-Server or bidirectional gateway is disrupted, the status bit (self-controlled mode) is set (can be evaluated for service diagnostics). After the malfunction has been rectified (details can be found in the documentation of the MSG-Server or bidirectional gateway), the MSG-Server or bidirectional gateway is automatically resynchronized.

NOTE: This product only supports EnOcean telegrams. When selecting a MSG-Server or bidirectional gateway, ensure that EEP A5-20-01 (Battery Powered Actuator) will be supported.

Actuator mode

If a new valve position telegram has been received from an external MSG-Server or bidirectional gateway, the internal control loop is not active. SAB05 moves to the commanded position, which has been calculated by the MSG-Server or BMS controller.

Self-controlling operation

If the telegram contains room temperature and set point instead of a valve position (DB_1.Bit_2 = 1), the SAB05 performs the control loop.

- Without room temperature sensor (= self-controlled mode):

Without a room temperature sensor, the temperature is controlled by a fixed set point of 20 °C using the integrated temperature sensor (actual value) and SAB05's integrated control loop.

- With room temperature sensor (EnOcean technology):

Room temperature and set point, optionally occupancy signals are transmitted via an EnOcean telegram (EEP A5-20-01). SAB05's integrated control algorithm makes room control easy and convenient.

Automatic closing point control

The small actuator continuously monitors the fully closed position and corrects it if necessary.

Frost protection function

If the temperature of the integrated temperature sensor drops below 6°C, SAB05 will open the valve until the temperature will raise to 8 °C in order to avoid damages in the HVAC system.

» CONFIGURATION VIA AIRCONFIG

Pressing the LRN-Button all parameters will be read and displayed in airConfig. Internal values and set parameters are displayed in the section [Device]. They are configurable in the section [Send].

The screenshot shows the 'Device' configuration page in the airConfig software. At the top, there are tabs for 'Device', 'Counter', 'Special', and 'Send'. The 'Device' tab is active. Below the tabs, there are several configuration fields:

- Device type:** Radio buttons for SAB10 and SAB05. SAB05 is selected.
- Operation:** Radio buttons for not learned, PerfectPair, and EEP. EEP is selected.
- Version Dolphin:** Text input field with value 0x0000.
- Version ATmega:** Text input field with value 0x0000.
- Master ID:** Text input field with value 0x00000000.

Below the configuration fields, there is a 'Device Status' section with three read-only fields:

- Actual temperature:** Text input field with value 0 °C.
- Actual position:** Text input field with value 0 %.
- Actual battery voltage:** Text input field with value 0.0 V.

Device type

The device type will be recognized automatically.

Operation

Describes the operating mode.

Version Dolphin/ Version ATmega/ Master ID

The current version of the dolphin chip, ATmega and the Master ID will be shown.

Device Status

All values that can be obtained in airConfig are updated with every wakeup cycle of the valve actuator. The shown value of the internal temperature transducer will be used for the frost protection function.

Actual valve position displayed in percent.

The battery voltage is okay if >3,6 V (SAB05)

| Actuator Status | |
|--|---|
| <input type="checkbox"/> Window open | <input type="checkbox"/> Temperature sensor failure |
| <input type="checkbox"/> Blockage | <input checked="" type="checkbox"/> Low battery |
| <input type="checkbox"/> Active | <input type="checkbox"/> Service |
| Device Configuration | |
| <input type="checkbox"/> Position interpolation | |
| <input type="checkbox"/> automatic summer mode detection | <input type="checkbox"/> Window open detection |
| <input type="checkbox"/> Valve protection | |
| <input type="checkbox"/> Auto send configuration | |

Windows open

The valve will be closed for 30 minutes if an open window was detected. (See window open detection)

Blockage

If the valve actuator can't set the required position, the blockage will be notified.

Active

Self-controlling operation is basically active. The actuator performs a drive on a safe default position. This function is disabled, if the battery capacity is <10 %.

Temperature sensor failure

Invalid value of the internal temperature transducer triggers a sensor failure.

Low battery

The battery capacity is continuously monitored. If the battery capacity is too low, a wireless signal is transmitted to the MSG-Server or bidirectional gateway and two audible signal tones are emitted every 6 hours. Once this message is activated, the remaining capacity of the batteries is <10%.

NOTE: The batteries must be replaced within the next 30 days.

As the battery level decreases, the interval between the audible signals becomes shorter and the number of signal tones increases to 4 signal tones every 3 hours. Prior to the remaining battery capacity being insufficient to maintain motorized operation, the actuator will move to and remain at a safe default position of approx. 50%. The wireless communication will continue as long as the batteries last.

Service (Interruption of radio communication)

If the communication with the MSG-Server or bidirectional gateway is interrupted for more than 60 minutes, the SAB05 switches to self-controlled and the status bit (self-controlled mode) is activated. When a correct telegram is received, the SAB05 automatically returns to normal operation.

Position interpolation

If active, the valve position will be interpolated.

Automatic summer mode detection

If "Summer mode on" is received by the MSG-Server or bidirectional gateway, SAB05 will close the valve and the transmission/reception interval is permanently set to 60 minutes in order to save energy.

Valve protection

Valve protection prevents the cone from jamming when the valve is inactive for a long time (i.e during summer). When valve protection is active, the actuator performs a displacement of 50% once every 21 days.

If the remaining battery level is <10% (see "Battery monitoring" section), this function is inactive.

This function can be switched on and off (see handling section).

Auto send configuration

The wireless radiator valve actuator sends its configuration every 24 hours if active. These data can be obtained with airConfig or gateway.

Window open detection (Energy hold off) not recommended

An open window is characterized by a large and rapid temperature drop at the SAB05. If such a temperature drop is sensed by the internal temperature sensor, SAB05 closes the valve for 30 min. During this time the actuator cannot be controlled. After 30 minutes, SAB05 returns to normal operation assuming the window will be closed by then. The automatic "Window open" recognition function is active again.

If the remaining battery level is <10% (see "Battery monitoring" section), this function is inactive.

This function can be switched on and off (see handling section).

Device Counter **Special** Send

Counter

This area contains all information about the counter, previously detected valve travel, the FlyWheel timer and the communication.

Device Counter **Special** Send

Settings

Total lift: mm

Lift to gasket: mm

Tn Value: minutes

Xp Value: °C

Signal Strength

Signal-Strength: db

Special

During commissioning, the actuator detects the fully closed position and the total stroke of the valve.

Once the batteries have been replaced or once the unit has been successfully paired with a MSG-Server or bidirectional gateway, this detection process can be performed again using the Run init sequence command (Set DB_1,Bit_7).

Device Counter **Special** Send

Transmit Clocking

Transmit time in EEPROM mode: minutes

Keep previous

Device Configuration

Position interpolation

Valve protection

Window open detection

Auto send configuration

Keep previous

Tn / Xp

Tn Value: minutes

Xp Value: °C

Keep previous Keep previous

Transmit Clocking

Configurable 1..120 min

Device Configuration

The parameter described in the section [Device] can be switched on or off.

Tn/Xp

If the control behavior in a closed loop from previous attempts is known, an adjustment of the control parameters can also be carried out due to the controlled variable.

» OVERVIEW OF FUNCTIONS - CONFIGURATION WITH THE LEARN-BUTTON

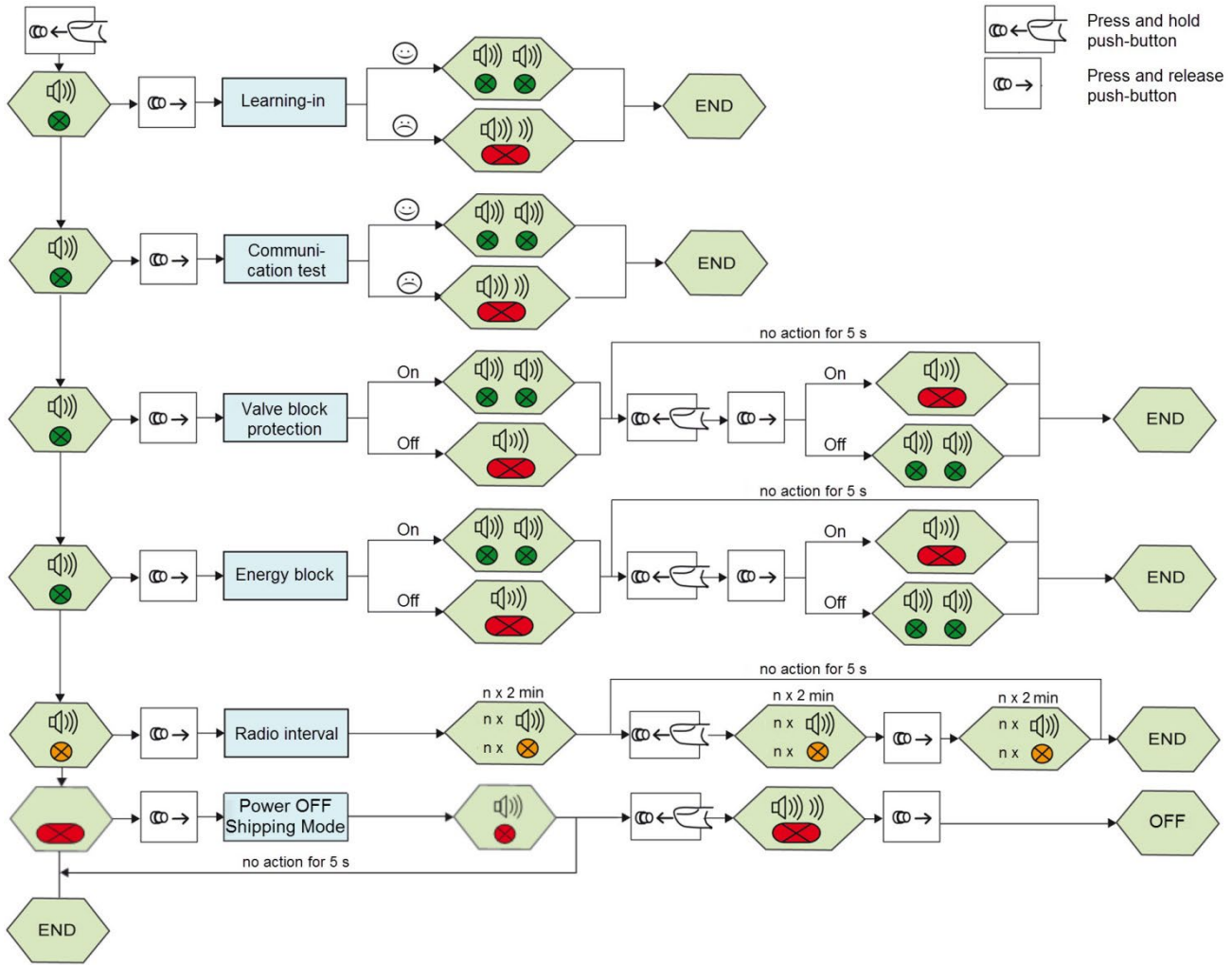

NOTE:

In addition to these instructions, the product descriptions of other system components, such as MSG-Server or bidirectional gateways, must be observed.

1 - Learn-in procedure

IMPORTANT! For the teach-in process it is necessary that the SAB+ is mounted on a heating valve.

→ This is important so that the valve drive can correctly perform the reference operation.

- Set the MSG-Server or bidirectional gateway to learn-in mode (3). For details see documentation of the MSG-Server or bidirectional gateway.
- To trigger a learn-in radio telegram at the SAB05, press and hold the push-button until a signal tone is heard and the Status LED lights up **green** (4).
- Release the push-button. Learn-in procedure is started (5). The MSG-Server or bidirectional gateway confirms the learn-in process to be successful. For details see the documentation of the MSG-Server or bidirectional gateway.
- The SAB05 confirms that the learn-in process has been successful (6/7) visually (Status-LED flashes **2 times in green**) and audible (**2 signal tones**). An initialization run is automatically carried out.
- Close the housing of the SAB05 by snapping on the cover (8).

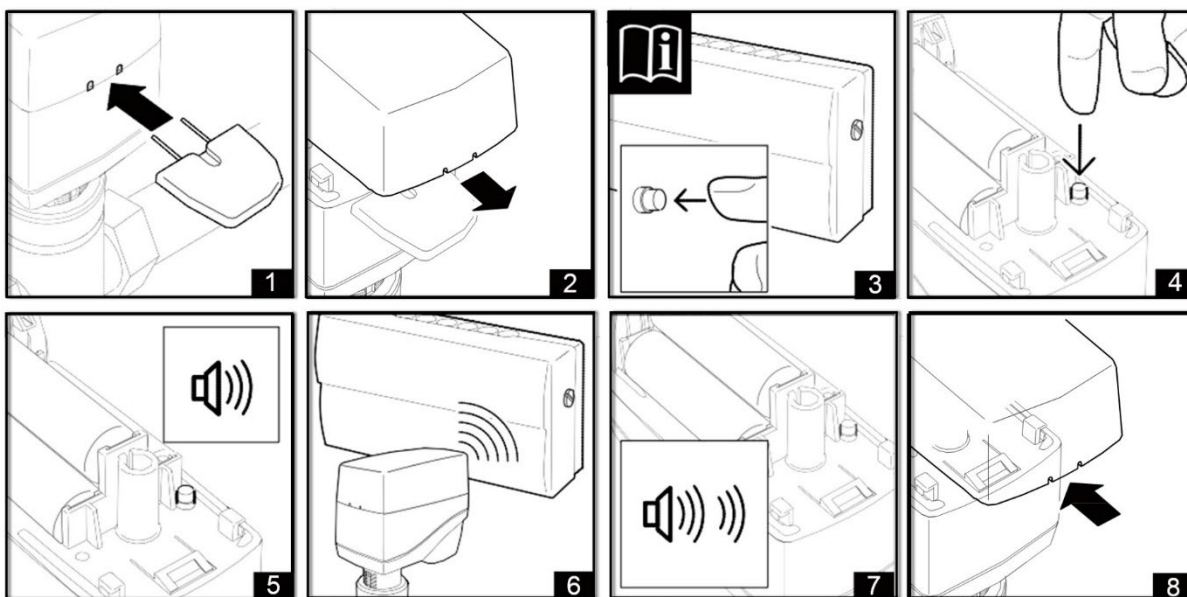

Notes:

After the learn-in procedure has been completed successfully, the device ID of the MSG-Server or bidirectional gateway is permanently stored in the SAB05. There is no need to repeat the learn-in procedure again after replacing the batteries.

If the learn-in process was **not successful**, this is indicated visually (Status-LED flashes **red** for **approx. 1 s**) and audible (downward sequence of tones). Restart the learn-in process.

It is not possible to delete the device ID of the MSG-Server or bidirectional gateway which is saved internally in the SAB05. The ID will be overwritten by the new wireless ID, when a new learn-in process is performed.

2 - Performing a communication test

- Press the push-button and hold it until you hear **2** successive signal tones and the status LED flashes **green 2 times**. Release the push-button.
- After the push-button has been released, the radio communication path to the MSG-Server or bidirectional gateway is checked. A successful communication test is indicated visually (status LED flashes **green 2 times**) and audible (2 signal tones). A successful communication test may require an adjustment of the current valve position.
- If the communication test has not been successful, it will be indicated visually (status LED flashes **red** for **approx. 1 s**) and audibly (downward sequence of tones). In case of a non-successful communication test, check the MSG-Server or bidirectional gateway and the wireless path.

3 - Switching the Valve Block Protection Feature On and Off

- Press the push-button and hold it until you hear **3** successive signal tones and the Status-LED flashes **green 3 times**. Release the push-button.

After the push-button has been released, the current status (ON or OFF) is indicated visually and audibly.

Valve block protection feature on: Status LED flashes **green 2 times** and **2** signal tones are emitted

Valve block protection feature off: Status LED flashes **red** for approx. **1 s** and a long signal tone is emitted

- To change the status, the push-button has to be pressed and released within **5s**.

The new function setting, either "valve block protection feature on" or "valve block protection feature off," is indicated visually and audibly as described above. **Factory setting: ON**

4 - Switching the Energy Block Feature (Automatic "Window Open" Recognition) On and Off

- Press the push-button and hold it until you hear **4** successive signal tones and the Status-LED flashes **green 4 times**.

Release the push-button. After the push-button has been released, the current status (ON or OFF) is indicated visually and audibly.

Energy block feature on: Status LED flashes **green 2 times** and **2 signal tones** are emitted

Energy block feature off: Status LED flashes **red** for **approx. 1 s** and a long signal tone is emitted

- To change the status, the push-button has to be pressed and released within 5s.

The new function setting, either "energy block feature ON" or "energy block feature OFF," is indicated visually and audibly as described above.
Factory setting: ON

5 - Setting the radio communication interval

The transmission/reception interval can be set in 2 min increments from 2 min up to 20 min.

- Press the push-button and hold it until you hear **5** successive signal tones and the status LED flashes **green 4 times** and **orange 1 time**.
Release the push-button.

After the push-button has been released, the current radio communication interval is indicated visually and audibly.

| Wake up interval | Signal |
|------------------|--|
| 2 min | Status-LED flashes 1x and 1 signal tone is emitted |
| 4 min | Status-LED flashes 2x and 2 signal tones are emitted |
| .. | .. |
| 20 min | Status-LED flashes 10x and 10 signal tones are emitted |

- To change the radio communication interval, the push-button has to be pressed and released within **5 s** several times, until the desired radio communication interval has been reached. The result is indicated visually and audibly as shown in above table "Wake up interval".
- Release the push-button. The new radio communication interval is acknowledged once more visually and audibly; **Default setting: Wake up interval: 10 min**

6 – End of the configuration

- To end the setting procedure, press and hold the push-button until **6** successive signal tones are heard and the Status-LED flashes 6 times, the Status-LED lights up red and a long signal tone (approx. 1 s) is emitted, the setting procedure is ended.

» DISMOUNTING ADVICE

- Open the battery compartment cover using the key supplied (1) by inserting it into the intended place.
- Remove the cover (2).
- Remove the batteries (3).
- Loosen the union nut (4/5).
- Remove the SAB05 from the valve (6).

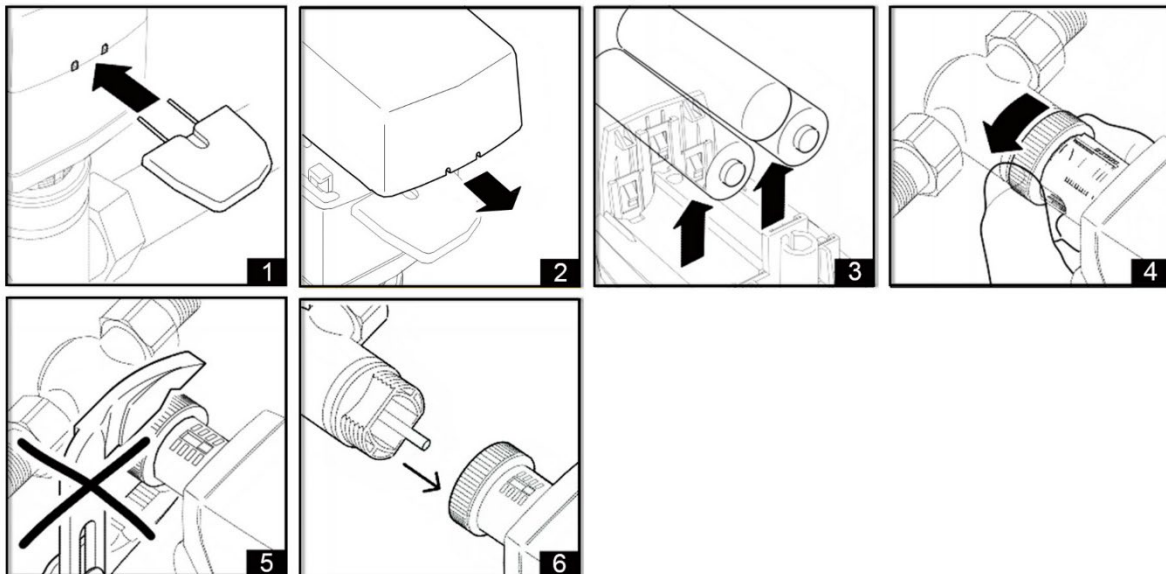

» BATTERY CHANGE

- Open the battery lid using the key supplied (1) by inserting both pins into the intended place (2). Remove the cover (3).
- Remove the batteries (4).
- Insert new batteries and briefly press the push-button (5/6).
- Close the battery lid (7).

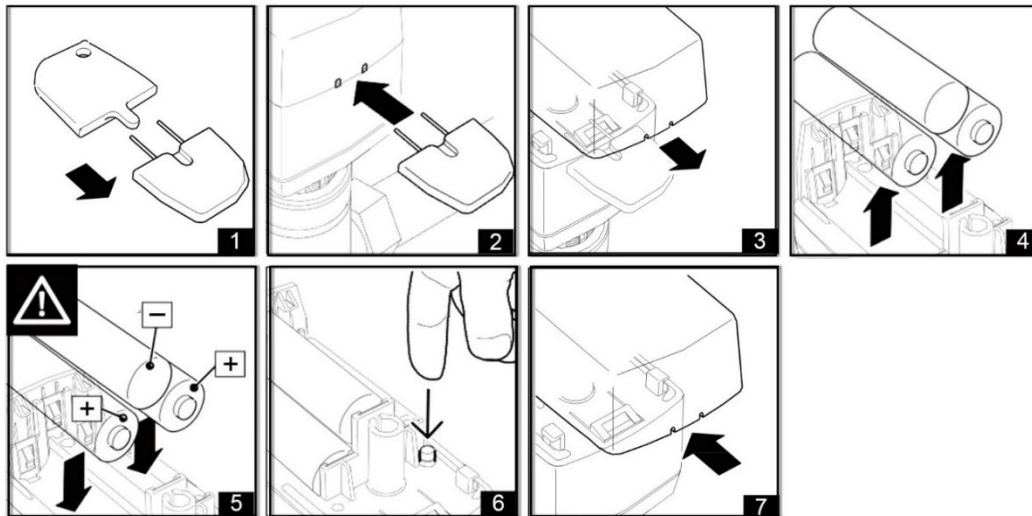

NOTE - Insert the batteries with the correct polarity marked in the battery compartment. Only use alkaline batteries (type: AA, LR6 1,5 V). Do not use rechargeable batteries.

Notes:

After replacing the batteries, SAB05 starts in delivery status with the actuator's spindle fully retracted. After the SAB05 receives a wireless telegram, normal operation is started.

While batteries are inserted, the SAB05 remains operational when taken off the radiator valve. Wait after replacing the batteries until SAB05 has fully retracted its spindle (delivery status) before reassembling on the valve.

» DIMENSIONS (MM)

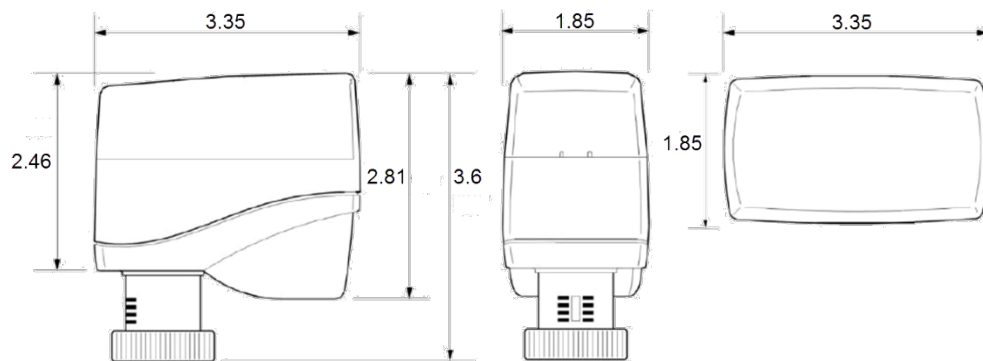

» ACCESSORIES (OPTIONAL)

Z220 Battery protection (protection for the union nut)
VS3 Vandalism protection (screwable cover)

Item No. 595612
Item No. 595605

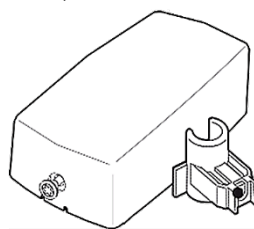

Z220

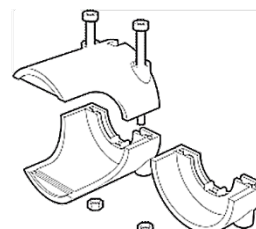

VS3