

WRF06 INC KNX

Flush mounting room operating panel

thermokon[®]
HOME OF SENSOR TECHNOLOGY

Datasheet

Subject to technical alteration
Issue date: 01.07.2024 • A140



» APPLICATION

Room control unit for setpoint / fan speed adjustment, presence detection and ECO mode function. Integrated sensors for recording the room temperature and humidity. The setpoint is adjusted in a configurable range using the rotary pushbutton and visualized by seven LEDs. All parameters can be reset via BUS. Typical areas of application are office buildings, hotels or residential buildings. The innovative and self-explanatory operation offers the functions of setpoint adjustment and fan control for intelligent room automation. The setpoint can be changed as required by turning the encoder within a previously defined range, e.g. -3K...+3K. The current status of the setpoint adjustment is visualized by LEDs.

» TYPE OVERVIEW

Room Operating unit temperature + humidity

- WRF06 INC Temp_rH KNX pure white matt
- WRF06 INC Temp_rH KNX pure white brilliant

- WRF06 INC FS5 Temp_rH KNX pure white matt
- WRF06 INC FS5 Temp_rH KNX pure white brilliant

» OPERATION- AND DISPLAY ELEMENTS

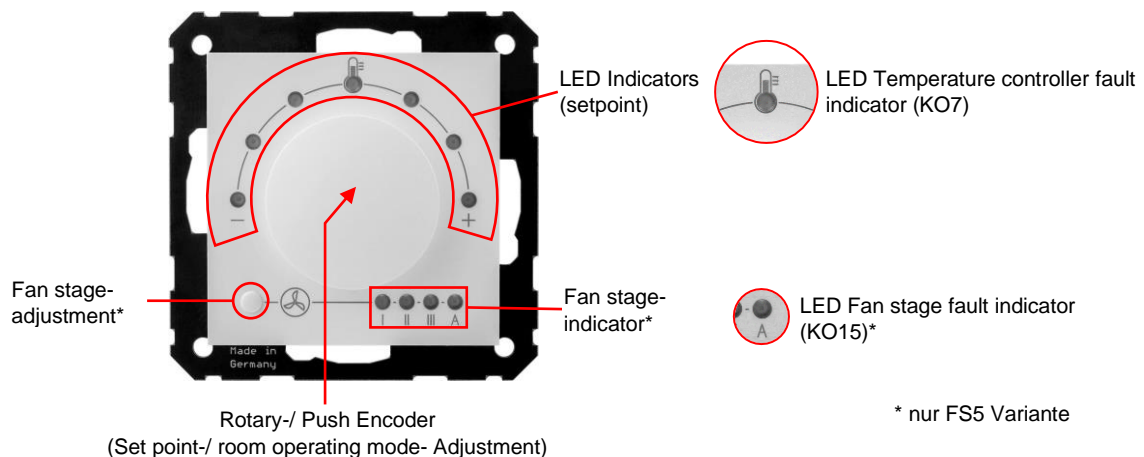

» SECURITY ADVICE – CAUTION

The installation and assembly of electrical equipment should only be performed by authorized personnel.



The product should only be used for the intended application. Unauthorised modifications are prohibited! The product must not be used in relation with any equipment that in case of a failure may threaten, directly or indirectly, human health or life or result in danger to human beings, animals or assets. Ensure all power is disconnected before installing. Do not connect to live/operating equipment.

Please comply with

- Local laws, health & safety regulations, technical standards and regulations
- Condition of the device at the time of installation, to ensure safe installation
- This data sheet and installation manual

» PRODUCT TESTING AND CERTIFICATION



Declaration of conformity

The declaration of conformity of the products are available on our website
<https://www.thermokon.de/direct/en-gb/categories/wrf06-inc>

» NOTES ON DISPOSAL



The crossed-out wheeled bin symbol indicates that the product or removable batteries must not be disposed of with household or commercial waste. Within the EU, you are legally obliged to dispose of the product separately and appropriately in accordance with the national laws of your country. Alternatively, please contact your supplier or Thermokon Sensortechnik GmbH. Further information can be found at: www.thermokon.com

» BUILD-UP OF SELF-HEATING BY ELECTRICAL DISSIPATIVE POWER

The electrical power loss of sensors with electronic components can influence the temperature measurement and is dependent on the respective operating voltage. This power loss must be taken into account in the temperature measurement. With a fixed operating voltage (± 0.2 V), this is usually done by adding or subtracting a constant offset value.

Calibration and adjustment should be carried out after installation.

Caution: Draughts are better at dissipating the power loss at the sensor. This results in temporary deviations in the temperature measurement.

» TECHNICAL DATA

Measuring values	Temperature, humidity	
Network technology	KNX (TP1)	
Power supply	Supply via BUS, 29 V = SELV	
Power consumption	< 1 W (29 V =)	
Measuring range temp	-10..+50 °C	
Accuracy humidity	typ. $\pm 0,3$ K (typ. at 21 °C)	
Measuring range Feuchte	Relative humidity 0..100% rH	Dewpoint 0..+50 -20..+80°C
Accuracy humidity	$\pm 2\%$ between 10..90% rH (typ. at 21 °C)	
Control function	Temperature set point adjustment, fan stage adjustment, standby/presence detection, ECO Mode, status feedback via LED	
Display	7 LEDs for display of set point adjustment and 1 LED for display of ECO-mode function	
Control elements	Encoder, with button function for room operating mode switch, button	
Enclosure	PC V0 in switch frame range	
Protection	IP30 according to EN 60529	
Connection electrical	Removable plug-in terminal, max. $\varnothing=0.8$ mm	
Ambient condition	-10..+50 °C, max. 85% rH non-condensing	
Mounting	flush mounted in standard EU box ($\varnothing=60$ mm), depth min. 45 mm.	

» MONTING ADVICE

The device is designed for mounting on a flush-mounted box. In addition to the technical specifications, the accuracy of the room sensors is influenced by the positioning and type of installation.

The bus cable is connected to the device via a plug-in terminal. The plug-in terminal must be removed from the device for prewiring.

The device is attached to the screws provided in the installation box (max. screw torque 0.8 Nm).

During Assembly:

- Installation type, air draught, heat source, radiation heat or direct sunlight can affect the measurement.
- Building material specific properties of the installation place (*brick-, concrete-, partition wall, cavity wall, ...*) can affect the measurement.
- Seal mounting box and (if present).
- Support ring must lie flat on the wall and must not be painted or wallpapered over

Assembly not recommendet in...

- Air draught (e.g.: close to windows / doors / fans ...)
- Near heating sources,
- Direct sunlight
- Niches / between furniture / ...

» CONNECTION PLAN

The WRF06 INC KNX is wired via KNX terminals.

Red	KNX +
Black	KNX -

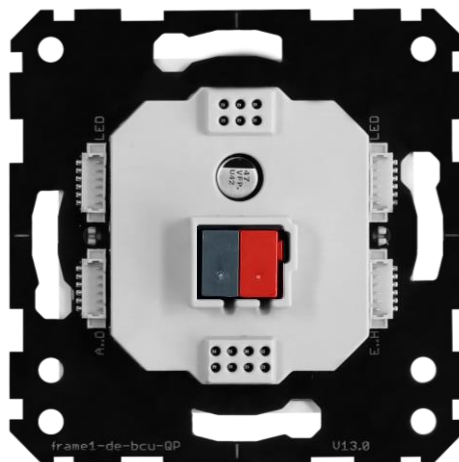

» GROUP OBJECTS

Depending on the version and configuration, certain communication objects are hidden or not available. In the following, the communication objects are structured according to their function and described accordingly.

The description contains the identification number (no.), the name and the object function, the data point type, the effective direction (input = receive / output = send), a description of the function and parameter-specific dependencies.

NB.	NAME	DPT	DESCRIPTION	DEPENDENCIES
0	Input Specified Temp.-Setpoint EIS5	9.001	Temperature setpoint is specified	<i>Temperature-Setpoint > usage: enabled</i>
1	Output Temp.-Setpoint EIS5	9.001	Set temperature setpoint is output	
3	Input default HVAC mode	20.102	Changeover of the room operating mode is specified	
4	Output HVAC mode	20.102	Room operating mode is output	
5	Input specified presence button	1.018	Specify switchover from Comfort to ECO/Standby	
6	Output presence	1.018	Output comfort switchover to ECO/Standby	
7	Input temperature controller fault	1.011	Fault indication LED Switch temperature controller If the climate actuator has a Group Object for fault indication, this can be linked with Group Object 7 and visualize the fault of the actuator. (middle setpoint LED lights up red)	
8	Input fan stage	5.001	Specify fan stage	<i>Fan control > usage: enabled</i>
9	Output fan stage	5.001	Output active fan stage	
10	Output fan stage Automatic Mode	1.003	Output active automatic fan stage	
11	Output fan stage 0 / AUS active	1.001	Output active fan stage 0/OFF	
12	Output fan stage 1 active	1.001	Output active fan stage 1	
13	Output fan stage fe 2 active	1.001	Output active fan stage 2	
14	Output fan stage 3 active	1.001	Output active fan speed 3	
15	Input fan control fault	1.011	Switching the fan control fault indicator LED If the fan actuator has a KO for fault indication, this can be linked with KO 15 and visualize the fault of the actuator. (AUTO LED lights up red)	
31	Output dewpoint EIS5	9.001	Output dew point value	<i>Temperature and humidity > temperature sensor: enabled Temperature and humidity > rel. humidity sensor: enabled</i>
66	Input day / night Switchover	1.024	LED brightness profile switchover	<i>general > day / night switching input object: enabled</i>
67	Output Temperature EIS5	9.001	Output temperature value	<i>Temperature and humidity > Temperature sensor: enabled</i>
68	Output rel. Humidity EIS5	9.007	Output relative humidity	<i>Temperature and humidity > rel. humidity sensor: enabled</i>
69	Output Sensor Status	1.011		<i>Temperature and humidity > Temperature sensor: enabled Temperature and humidity > rel. humidity sensor: enabled</i>
70	Input ext. Temperature EIS5	9.001	External Temperature sensor	<i>Temperature and humidity > Temperature sensor: enabled Temperature and humidity > external temperature input object: enabled</i>

» FLAGS

The communication behavior of the individual objects is determined by the so-called flags.

FLAG	DESCRIPTION
K-Flag	Activate / deactivate communication of objects.
L-Flag	Object reacts to a GroupValueRead telegram coming from the bus and sends a GroupValueResponse telegram to the bus. (set flag)
S-Flag	Object reacts to a GroupValueWrite telegram coming from the bus and overwrites the previous object value. (set flag)
Ü-Flag	Object outputs each updated value: it sends a GroupValueWrite telegram to the bus. (set flag)
A-Flag	The device will respond to a GroupValueResponse telegram coming from the bus for this object, so it overwrites the object value. For a switching actuator, for example, this means that a relay representing this object is opened or closed. (set flag)

» ETS- CONFIGURATION PARAMETER

PARAMETER PAGE	PARAMETER	DESCRIPTION
General	Device name	
	Button input debounce time	<i>Not relevant for this application.</i>
	Day/night switching input object	Activates/deactivates the group object for day/night switching of the LED brightnesses
	Center LED1 mode	<i>Not relevant for this application.</i>
	Center LED2 mode	<i>Not relevant for this application.</i>
Temperature and humidity	Temperature sensor	Enables / disables the parameter dialog and the group object
	Temperature offset in 1/10K (is added to temp. value: -100..100)	Defines the offset value for the measured variable.
	Send when temperature changes	Defines the change at which the Group Object sends the measured value.
	Rel. Humidity	Enables / disables the parameter dialog and the Group object
	Rel. Humidity offset in % (is added to humid. value: -10..10)	Defines the correction value for the measured variable.
	Send when rel. humidity changes	Defines the change at which the Group Object sends the measured value.
	Time for cyclic sending (0..1020s) (0 = cyclic sending disabled)	Defines the time for the cyclical sending of the measured values.
	External temperature input object	Enables / disables the parameter dialog and the group object
	Mixing ratio of Tint and Text	Defines the mixing ratio of internal (tint) to external (text; via Group Object 70) temperature value.
	Temperature setpoint	Usage
LED brightness (day, operation)		Defines the LED brightness for daytime operation (day/night switchover via Group Object 66)
LED brightness (day, standby)		Defines the LED brightness for standby during the day
LED brightness (night, operation)		Defines the LED brightness for operation at night (day/night switchover via Group Object 66)
LED brightness (night, standby)		Defines the LED brightness for standby at night
Min. temperature -setpoint °C		
Max. temperature -setpoint °C		
At buspower recovery temperature set point is		Defines the setpoint after bus voltage recovery.
Temperature set point cyclic sending		Enables / disables the parameter dialog
Time for cyclic sending (600..14400s)		Defines the time for the cyclical sending of the setpoint.
Occupancy key / HVAC mode		Enables / disables the parameter dialog and the group object
Occupancy key states		Specifies the room operating modes that are switched by the presence button.
Duration of occupancy (retriggerable)		Defines the presence delay time
Fan control	Usage	Enables / disables the parameter dialog and the group object
	LED brightness (day, operation)	Defines the LED brightness for operation during the day (day/night switchover via group object 66)
	LED brightness (day, standby)	Specifies the LED brightness for standby during the day
	LED brightness (night, operation)	Specifies the LED brightness for operation at night (day/night switchover via group object 66)
	LED brightness (night, standby)	Defines the LED brightness for standby at night
	Fan stage „AUTO“	Activates/deactivates the group object
	Number of fan stages	Defines the number of fan levels
	At bus power recovery set fan stage to	Specifies the fan level after bus voltage recovery.
Button input E+F	<i>Not relevant for this application.</i>	<i>Not relevant for this application.</i>
Button input G+H	<i>Not relevant for this application.</i>	<i>Not relevant for this application.</i>
LED Output E / Logic E	<i>Not relevant for this application.</i>	<i>Not relevant for this application.</i>
LED Output F / Logic F	<i>Not relevant for this application.</i>	<i>Not relevant for this application.</i>
LED Output G / Logic G	<i>Not relevant for this application.</i>	<i>Not relevant for this application.</i>
LED Output H / Logic H	<i>Not relevant for this application.</i>	<i>Not relevant for this application.</i>

» **DIMENSIONS (MM)**

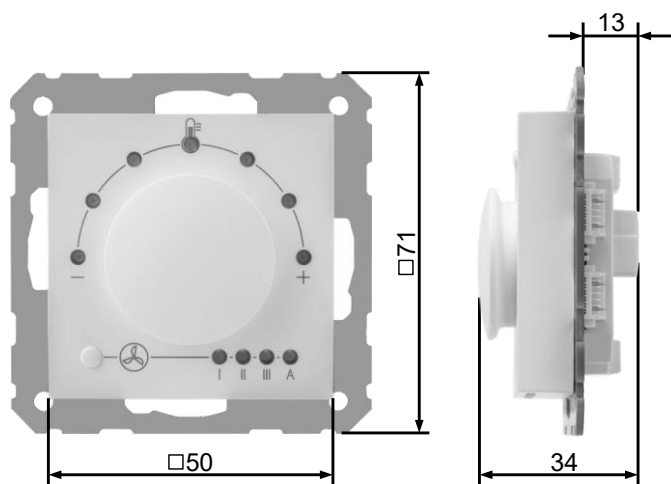

» **ACCESSORIES (OPTIONAL)**

Thermokon USB Interface KNX

Item No. 806190