

LK+ CO2+VOC (LCD) (Temp_rH) RS485 Modbus

Duct sensor for air quality, optional temperature and humidity

thermokon[®]
HOME OF SENSOR TECHNOLOGY

Datasheet

Subject to technical alteration
Issue date: 21.06.2023 • A122



The following illustrations show the version with LCD

» APPLICATION

Air quality sensor for measuring VOC air quality, CO₂, temperature and humidity in outdoor areas with 2 0..10 V output. LCD models with RGB background light have a transparent cover.

» TYPES AVAILABLE

Duct sensor CO₂ + VOC + temp + rH (opt.), optional with display – active RS485 Modbus MS/TP

- LK+ CO₂+VOC (LCD) RS485 Modbus
- LK+ CO₂+VOC (LCD) Temp RS485 Modbus
- LK+ CO₂+VOC (LCD) Temp_rH RS485 Modbus

optionally with shorter sensor tube, Type 100

- LK+ CO₂+VOC (LCD) 100 RS485 Modbus
- LK+ CO₂+VOC (LCD) 100 Temp RS485 Modbus
- LK+ CO₂+VOC (LCD) 100 Temp_rH RS485 Modbus

» SECURITY ADVICE – CAUTION

The installation and assembly of electrical equipment should only be performed by authorized personnel.



The product should only be used for the intended application. Unauthorised modifications are prohibited! The product must not be used in relation with any equipment that in case of a failure may threaten, directly or indirectly, human health or life or result in danger to human beings, animals or assets. Ensure all power is disconnected before installing. Do not connect to live/operating equipment.

Please comply with

- Local laws, health & safety regulations, technical standards and regulations
- Condition of the device at the time of installation, to ensure safe installation
- This data sheet and installation manual

» PRODUCT TESTING AND CERTIFICATION



Declaration of conformity

The declaration of conformity of the products are available on our website <https://www.thermokon.de/>.

» NOTES ON DISPOSAL



As a component of a large-scale fixed installation, Thermokon products are intended to be used permanently as part of a building or a structure at a pre-defined and dedicated location, hence the Waste Electrical and Electronic Act (WEEE) is not applicable. However, most of the products may contain valuable materials that should be recycled and not disposed of as domestic waste. Please note the relevant regulations for local disposal.

» GENERAL REMARKS CONCERNING SENSORS

Especially with regard to passive sensors in 2-wire conductor versions, the wire resistance of the supply wire has to be considered. If necessary the wire resistance has to be compensated by the follow-up electronics. Due to self-heating, the wire current affects the measurement accuracy, so it should not exceed 1 mA.

When using lengthy connection wires (depending on the cross section used) the measuring result might be falsified due to a voltage drop at the common GND-wire (caused by the voltage current and the line resistance). In this case, 2 GND-wires must be wired to the sensor - one for supply voltage and one for the measuring current.

Sensing devices with a transducer should always be operated in the middle of the measuring range to avoid deviations at the measuring end points. The ambient temperature of the transducer electronics should be kept constant. The transducers must be operated at a constant supply voltage ($\pm 0,2$ V). When switching the supply voltage on/off, onsite power surges must be avoided.

» BUILD-UP OF SELF-HEATING BY ELECTRICAL DISSIPATIVE POWER

Sensors with electronic components always have a dissipative power, which affects the temperature measurement of the ambient air. The dissipation in active temperature sensors shows a linear increase with rising operating voltage. This dissipative power has to be considered when measuring temperature. In case of a fixed operating voltage ($\pm 0,2$ V) this is normally done by adding or reducing a constant offset value.

Thermokon transducers can be operated with variable operating voltages. The transducers are set at the factory with a reference operating voltage of 24 V =.

At this voltage, the expected measuring error of the output signal will be the least. Other operating voltages, can cause a measurement deviation changing power loss of the sensor electronics.

A recalibration can be carried out directly on the unit or via a software variable (app or bus).

Remark: Occurring draught leads to a better carrying-off of dissipative power at the sensor. Thus temporally limited fluctuations might occur upon temperature measurement.

» APPLICATION NOTICE FOR HUMIDITY SENSORS

At regular environmental condition, it is recommended to calibrate the sensor annually to check the compliance with the accuracy required in the application. The following conditions can damage the sensor element or lead in long term to loss of the specified accuracy:

- Mechanical stress
- Contamination (e.g. dust / fingerprints)
- Aggressive chemicals
- Ambient conditions (e.g. condensation on measuring element)



Do not touch the sensor elements!

Re-calibration or exchange of the sensor element are not subject of the general warranty.

» INFORMATION ABOUT INDOOR AIR QUALITY CO₂

EN 13779 defines several classes for indoor air quality:

Category	CO ₂ content above the content in outdoor air in ppm		Description
	Typical range	Standard value	
IDA1	<400 ppm	350 ppm	Good indoor air quality
IDA2	400.. 600 ppm	500 ppm	Standard indoor air quality
IDA3	600..1.000 ppm	800 ppm	Moderate indoor air quality
IDA4	>1.000 ppm	1.200 ppm	Poor indoor air quality

» INFORMATION ABOUT SELF-CALIBRATION FEATURE CO₂

All gas sensors are subject to drift. The degree of drift is dependent on the use of components and product design. In addition, the following environmental conditions, among others, can accelerate/ favor the aging and wear of the sensors:

- Mechanical stress (also due to temperature fluctuation)
- Contamination (dust / fingerprints e.g.)
- Abrasive chemicals
- Environmental influences (high humidity / condensation on measuring element)

An internal self calibration function with dual channel technology compensates the caused drift. Thermokon sensors are for permanent use. (e.g. hospitals).

» APPLICATION NOTICE FOR AIR QUALITY SENSORS VOC

Volatile organic compounds (VOC) are gaseous and vaporous substances of organic origin in the air. VOC-sensors monitor the significant part of humanly olfactory sensed air quality. (e.g. body odor | tobacco smoke | odor of materials, furniture, carpets, paint, adhesives, ...)

The VOC-Value is an application-specific indication for air quality and doesn't provide any information about individual components of VOC

A VOC sensor oxidises the organic molecules that collide with it, which results in changing the resistance of the semiconductor.

Any contact with the sensitive sensors must be avoided and will invalidate the warranty.

The VOC Sensor is factory calibrated and can be calibrated via USEapp subsequently, if needed.

» APPLICATION NOTICE



The Bluetooth dongle snaps into the socket easily. When removing, please fix the plug-in card (option PCB) so that it is not unintentionally pulled out.

» CONFIGURATION



The Thermokon bluetooth dongle with micro-USB (Item No.: 668262) is required for communication between USEapp and USE-M / USE L products. Commercial bluetooth dongles are not compatible.



Application-specific reconfiguration of the devices can be carried out using the Thermokon USEapp. The configuration is carried out in the voltage-supplied state.



The configuration-app and the app description can be found in the Google Play Store or in the Apple App Store.

» TECHNICAL DATA

Measuring values <i>(type-dependent)</i>	CO ₂ , VOC, temperature and humidity	
Output voltage	2x 0..10 V or 0..5 V, min. load 10 kΩ (live-zero configuration via Thermokon USEapp)	
Network technology	RS485 Modbus, RTU, half-duplex, baud rate 9.600, 19.200, 38.400 or 57600, parity: none (2 stopbits), even or odd (1 stopbit), Fail-safe Biasing required	
Power supply	15..35 V = or 19..29 V ~ SELV <i>With alternating voltage, the correct polarity must be ensured</i>	
Power consumption	max. 2,3 W (24 V =) max. 4,3 VA (24 V ~)	
Measuring range temp. <i>(type-dependent)</i>	Temp Temp_rH 0..+50 °C (default setting) , optionally configured via Thermokon USEapp	
Measuring range humidity <i>(type-dependent)</i>	Temp_rH 0..100% rH non-condensing, optionally (enthalpy, absolute humidity, dew point)	
Measuring range CO ₂	0..2000 ppm (default), 0..5000 ppm (optionally configured via Thermokon USEapp)	
Accuracy temperature <i>(type-dependent)</i>	Temp Temp_rH ±0,5 K (typ. at 21 °C)	
Accuracy humidity <i>(type-dependent)</i>	Temp_rH ±2% between 10..90% rH (typ. at 21 °C)	
Accuracy CO ₂	±50 ppm +3% of reading (typ. at 21 °C, 50% rH)	
Air speed	min. 0,3 m/s, max. 12 m/s	
Calibration	self-calibration, Dual Channel	
Sensor	CO₂ NDIR (non-dispersiv, infrared)	VOC VOC sensor (heated metal oxide semiconductor)
Display <i>(optional)</i>	LCD LCD 29x35 mm with RGB backlight	
Enclosure <i>(type-dependent)</i>	enclosure USE-M, PC, pure white, with removable cable entry	LCD cover PC, transparent
Protection	IP65 according to EN 60529	
Cable entry	M25, for wire max. Ø=7 mm, seal insert for fourfold cable entry	
Pipe <i>(type-dependent)</i>	CO₂+VOC PA6, black, Ø=19,5 mm, length 150 mm Type 100 Length 70 mm	Temp Temp_rH PA6, black, Ø=19,5 mm, length 180 mm Type 100 Length 100 mm
Connection electrical	Mainboard removable plug-in terminal, max. 2,5 mm ²	Plug-in card removable plug-in terminal, max. 1,5 mm ²
Ambient condition	0..+50 °C, max. 85% rH short term condensation	
Notes	mixed gas sensors detect gases and vapours which can be oxidised (burnt): Body odours, tobacco smoke, exhalations emitted by materials (furniture, carpets, paint, glue ...)	

When several BUS devices are supplied by one 24 V AC voltage supply, it is to be ensured that all "positive" operating voltage input terminals (+) of the field devices are connected and all "negative" operating voltage input terminals (-) (=reference potential) are connected (in-phase connection of field devices). In the case of reversed polarity at one field device, a supply voltage short-circuit would be caused by that device.

The consequential short-circuit current flowing through this field may cause damage to it. Therefore, pay attention to correct wiring.

» **CONNECTION PLAN**

To change the output voltage range (default: 0..10 V to 0..5 V) via jumper, the display must be removed from the board first.

LK+ CO2+VOC (Temp_rH) (LCD) RS485

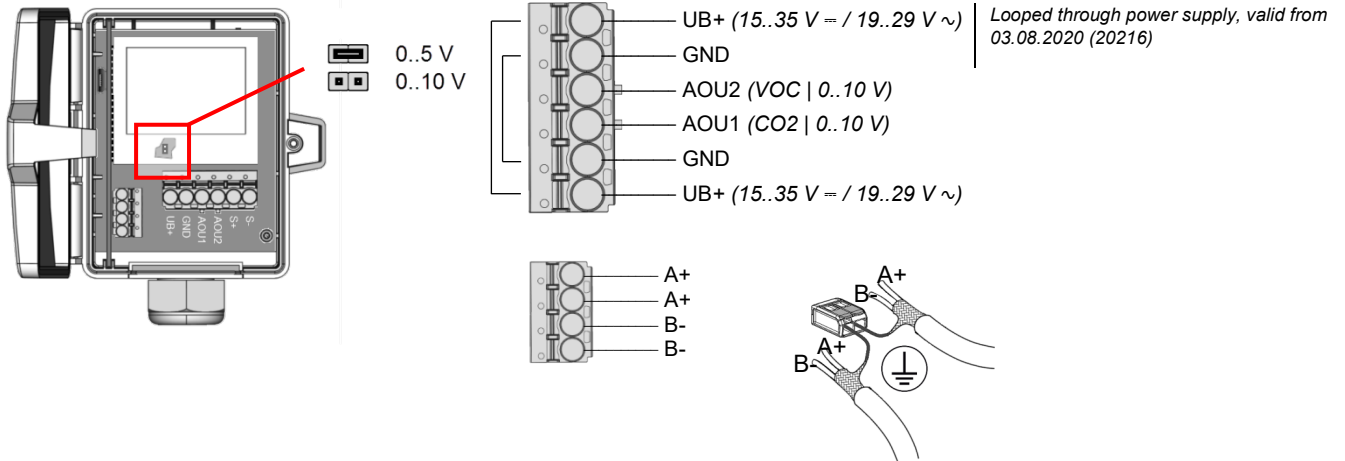

» **DIP SWITCHES, PLUG-IN CARD**

The Modbus address of the device is set in the range of 1 ... 31 (binary encoded) using a 5-pole DIP switch. With address 0 via DIP, an extended address range (32..247) is available via USEapp.

* factory default settings

Address	Access	Description	Resolution / Unit
1	R	relative humidity	0.1 %rF
5	R	CO2	1.0 Ppm
6	R	VOC	1.0 %
7	R	CO2 VOC MIX	1.0 %

Adress	Access	Description	Resolution / Unit					
			Register 400= 1		Register 400= 2			
0	R	Temperature	SI	0.1	°C	Imperial	0.1	°F
2	R	Absolute humidity	SI	0.01	g/m ³	Imperial	0.01	Gr/ft ³
3	R	Enthalpy	SI	0.1	kJ/kg	Imperial	0.1	BTU/lb
4	R	Dew point	SI	0.1	°C	Imperial	0.1	°F

Available measured values are type-dependent.



Modbus addresses:

USE-RS485 Modbus Interface

A detailed description of the Modbus addresses can be found under the following link: → [Download](#)

» DIMENSIONS (MM)

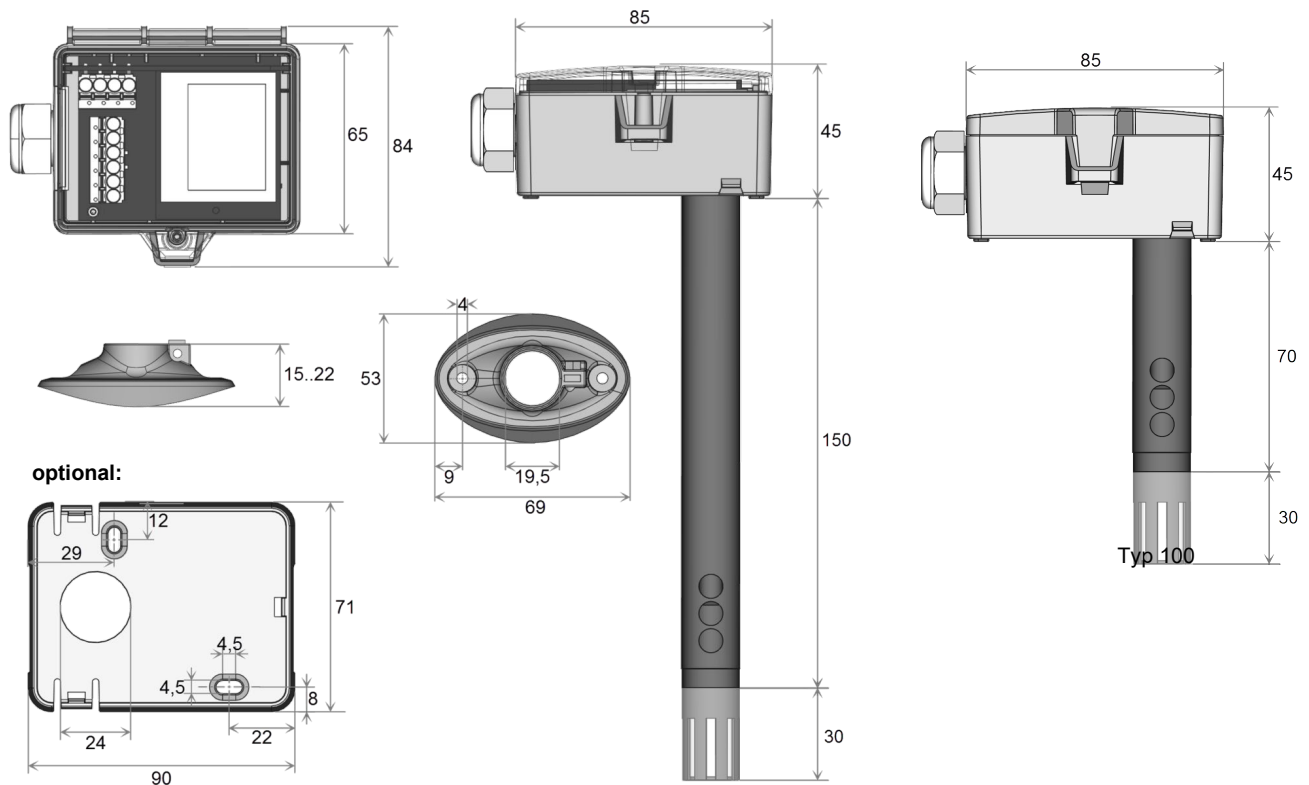

» ACCESSORIES (INCLUDED IN DELIVERY)

Mounting base

Item No. 631228

Mounting kit universal

Item No. 698511

• Cover screw + screw cover • 2 Rawlplugs • 2 Screws (countersunk head) • 2 Screws (rounded head)

» ACCESSORIES (OPTIONAL)

Bluetooth dongle

Item No. 668262

Filter stainless steel, wire mesh

Item No. 231169

RS485 Biasing Adapter

Item No. 811378

USB RS485 Modbus RTU Logger

Item No. 809917

USB Interface RS485 (incl. driver CD)

Item No. 668293