

Datasheet

Subject to technical alteration
Issue date: 18.04.2024 • A140



» APPLICATION

Ceiling mounted multi sensor designed for measuring light and motion in room and office spaces and typically used in lighting applications to optimize energy efficiency through lighting control and temperature reduction in unused rooms. Low profile design with various output signals compatible to all BMS manufacturers. For mounting on concrete ceilings an enclosure for surface mounting is available.

» TYPES AVAILABLE

Ceiling multi sensor light + motion – active 0..10 V (light), relay (motion)

- MDS Standard 1
optional to relay with "open collector" output (transistor)

Ceiling multi sensor light + motion + temperature – passive sensor (temperature), 0..10 V (light), relay (motion)

- MDS Standard 2 (VS)
optional to relay with "open collector" output (transistor)

Ceiling multi sensor light + motion + temperature – active 2x 0..10 V (light, temperature), relay (motion)

- MDS Standard 3 (VV)
optional to relay with "open collector" output (transistor)

» SECURITY ADVICE – CAUTION

The installation and assembly of electrical equipment should only be performed by authorized personnel.



The product should only be used for the intended application. Unauthorised modifications are prohibited! The product must not be used in relation with any equipment that in case of a failure may threaten, directly or indirectly, human health or life or result in danger to human beings, animals or assets. Ensure all power is disconnected before installing. Do not connect to live/operating equipment.

Please comply with

- Local laws, health & safety regulations, technical standards and regulations
- Condition of the device at the time of installation, to ensure safe installation
- This data sheet and installation manual

» PRODUCT TESTING AND CERTIFICATION



Declaration of conformity

The declaration of conformity of the products are available on our website
<https://www.thermokon.de/direct/en-gb/categories/mds>

» NOTES ON DISPOSAL



The crossed-out wheeled bin symbol indicates that the product or removable batteries must not be disposed of with household or commercial waste. Within the EU, you are legally obliged to dispose of the product separately and appropriately in accordance with the national laws of your country. Alternatively, please contact your supplier or Thermokon Sensortechnik GmbH. Further information can be found at: www.thermokon.com

» BUILD-UP OF SELF-HEATING BY ELECTRICAL DISSIPATIVE POWER

Sensors with electronic components always have a dissipative power, which affects the temperature measurement of the ambient air. The dissipation in active temperature sensors shows a linear increase with rising operating voltage. This dissipative power has to be considered when measuring temperature. In case of a fixed operating voltage ($\pm 0,2$ V) this is normally done by adding or reducing a constant offset value.

Thermokon transducers can be operated with variable operating voltages. The transducers are set at the factory with a reference operating voltage of 24 V =.

At this voltage, the expected measuring error of the output signal will be the least. Other operating voltages, can cause a measurement deviation changing power loss of the sensor electronics.

A recalibration can be carried out directly on the unit or via a software variable (app or bus).

Remark: Occurring draught leads to a better carrying-off of dissipative power at the sensor. Thus temporally limited fluctuations might occur upon temperature measurement.

» TECHNICAL DATA

Measuring values <i>(type-dependent)</i>	Brightness, motion, optional temperature	
Output passive <i>(type-dependent)</i>	PT100 PT1000 NTC1,8k NTC10k NTC50k other sensors on request	
Output voltage <i>(type-dependent)</i>	1..2x 0..10 V, min. Last 10 k Ω	
Output switching contact	motion floating contact (NO), max. 24 V 1 A, with follow-up time 1 second..30 minutes, adjustable at the device	
Power supply	15..24 V = ($\pm 10\%$) or 24 V ~ ($\pm 10\%$) SELV	
Power consumption	typ. 1,5 W (24 V =) 4 VA (24 V ~)	
Measuring range temp <i>(type-dependent)</i>	0..+50 °C	passive: depending on used sensor
Measuring range light	0..1000 Lux	
Accuracy temperature <i>(type-dependent)</i>	$\pm 0,5$ K (typ. at 21 °C)	
Accuracy light	± 50 Lux	
Detection range	Cone-shaped detection range, angle 105°, range > 5 m, 444 detection zones. With an installation height of 2,7 m circular detection range will have a D= 7 m.	
Sensor	PIR (passive infrared)	
Enclosure	ABS, pure white	
Protection	IP20 according to EN 60529	
Connection electrical	terminal, max. 1,5 mm ² , plugable	
Ambient condition	0..+50 °C, max. 85% rH non-condensing	
Notes	Enclosure for surface mounting available	

» ACCESSORIES (OPTIONAL)

Enclosure for surface mounting MDS pure white

Item No. 448512

» **MOUNTING ADVICES**

Mounting height

The mounting height has a direct influence on the range of the motion detector. The optimum mounting height is 2.70m. All other dimensions will change the range.

Fixed mounting

The motion detector must be mounted on a solid surface, as any movement of the detector will result in false alarms.

Distance to switched luminaires

In order to avoid unintentional switching on of the luminaire by the motion detector, the luminaire should not be mounted in the detection area of the motion detector. Also avoid mounting the motion detector above a luminaire. The heat radiation of the luminaire can influence the function of the motion detector and possibly lead to a false triggering of the detector.

Mounting sideways to the walking direction

For optimum motion detection, the detector must be mounted to the side of the detection area so that the zones are cut as vertically as possible. Mounting locations where the objects to be detected move directly onto the motion detector result in a significant reduction of the range.

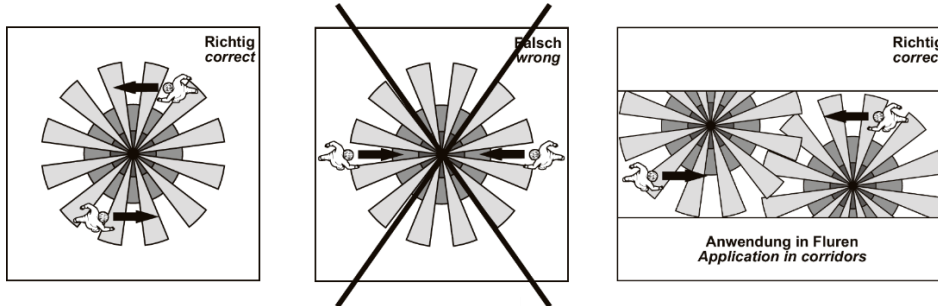

Distance to interference sources

To avoid false alarms, sources of interference such as radiators, lamps, air outlets from air conditioning systems, etc. should be outside the detection range. Direct sunlight should also be avoided.

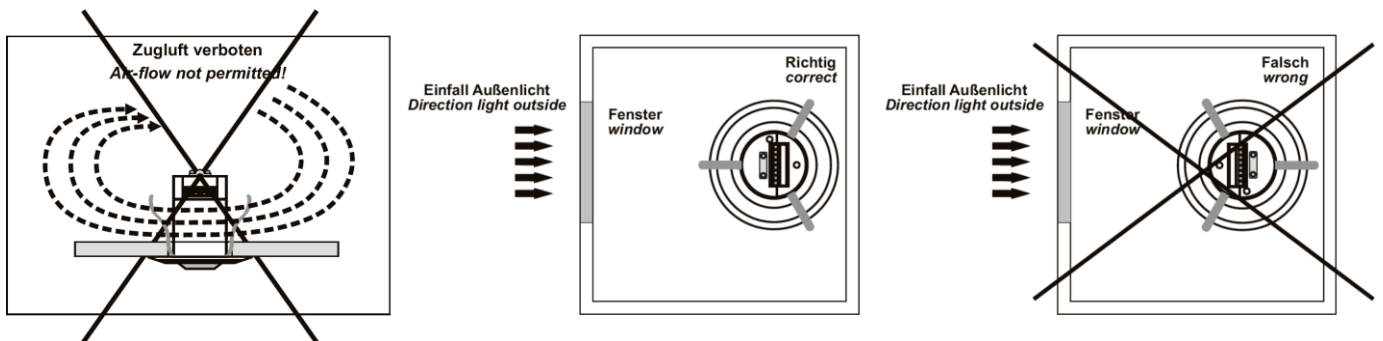

Feedback on detected movement

Motion detection by the sensor is signalled by the integrated signal LED (flashing for approx. 2 seconds). Note: The signalling LED is independent of the set follow-up time of the relay output. During initialisation of the device (voltage reset), the signalling LED and the relay output are switched on for approx. 45 seconds.

» **DETECTION RANGE**

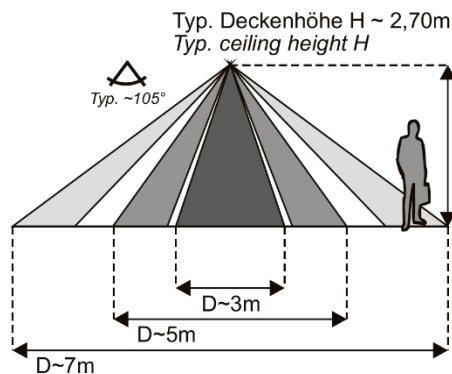

This sensor detects changes in infrared radiation that occur when a person (or object) moves whose temperature is different from the environment.

The specified ranges refer to average conditions at a certain installation height and are therefore to be regarded as guide values. The range can vary greatly with changing temperature conditions. The necessary temperature difference between the detectable object and the environment should be at least 4 K. The speed of the object should be at least 0.3 to 1.0 m/s.

» **CONNECTION PLAN**

Relay switch-off delay adjustable via potentiometer in the range from 1s to 30 min.

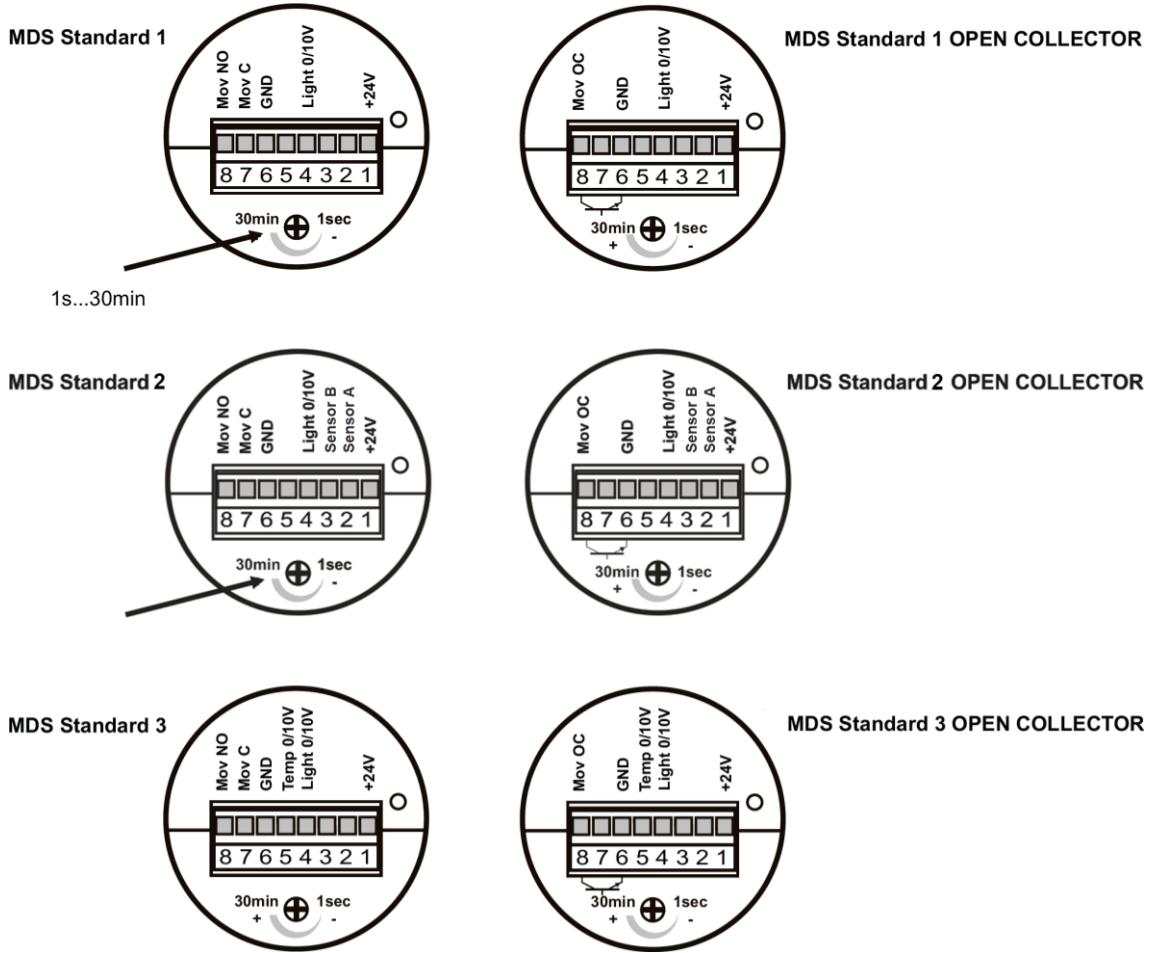

» **DIMENSIONS (MM)**

